

ELECTRICAL AND ELECTRONICS ENGINEERING
LECTURE NOTES

Course Title : POWER ELECTRONICS

Course Code : 23EE501

Regulation : NR23

UNIT – V

AC-AC Converters

5.1 Introduction to AC voltage controllers

AC voltage controllers (ac line voltage controllers) are employed to vary the RMS value of the alternating voltage applied to a load circuit by introducing Thyristors between the load and a constant voltage ac source. The RMS value of alternating voltage applied to a load circuit is controlled by controlling the triggering angle of the Thyristors in the AC Voltage Controller circuits.

In brief, an AC Voltage Controller is a type of thyristor power converter which is used to convert a fixed voltage, fixed frequency ac input supply to obtain a variable voltage ac output. The RMS value of the ac output voltage and the ac power flow to the load is controlled by varying (adjusting) the trigger angle „ α “



Figure: 3.1 Block diagram of AC voltage controller

5.2 Control strategies:

There are two different types of thyristor control used in practice to control the ac power flow

1. On-Off control
2. Phase control

These are the two ac output voltage control techniques. In On-Off control technique Thyristors are used as switches to connect the load circuit to the ac supply (source) for a few cycles of the input ac supply and then to disconnect it for few input cycles. The Thyristors thus act as a high speed contactor (or high speed ac switch).

5.2.1 Phase control

In phase control the Thyristors are used as switches to connect the load circuit to the input ac supply, for a part of every input cycle. That is the ac supply voltage is chopped using Thyristors during a part of each input cycle.

The thyristor switch is turned on for a part of every half cycle, so that input supply voltage appears across the load and then turned off during the remaining part of input half cycle to disconnect the ac supply from the load.

By controlling the phase angle or the trigger angle „ α “ (delay angle), the output RMS voltage across the load can be controlled.

The trigger delay angle „ α “ is defined as the phase angle (the value of ωt) at which the thyristor turns on and the load current begins to flow.

Thyristor AC Voltage Controllers use ac line commutation or ac phase commutation. Thyristors in AC Voltage Controllers are line commutated (phase commutated) since the input supply is ac. When the input ac voltage reverses and becomes negative during the negative half cycle the current flowing through the conducting thyristor decreases and falls to zero. Thus the ON thyristor naturally turns off, when the device current falls to zero.

Phase control Thyristors which are relatively inexpensive, converter grade Thyristors which are slower than fast switching inverter grade Thyristors are normally used.

For applications upto 400Hz, if Triacs are available to meet the voltage and current ratings of a particular application, Triacs are more commonly used.

Due to ac line commutation or natural commutation, there is no need of extra commutation circuitry or components and the circuits for AC Voltage Controllers are very simple.

Due to the nature of the output waveforms, the analysis, derivations of expressions for performance parameters are not simple, especially for the phase controlled AC Voltage Controllers with RL load. But however most of the practical loads are of the RL type and hence RL load should be considered in the analysis and design of AC Voltage Controllers circuits.

5.3 Type of ac voltage controllers

The ac voltage controllers are classified into two types based on the type of input ac supply applied to the circuit.

- Single Phase AC Controllers
- Three Phase AC Controllers

Single Phase AC Controllers operate with single phase ac supply voltage of 230V RMS at 50Hz in our country. Three Phase AC Controllers operate with 3 phase ac supply of 400V RMS at 50Hz supply frequency.

Performance parameters of ac voltage controllers

- RMS Output (Load) Voltage

$$V_{\alpha(RMS)} = \left[\frac{n}{2\pi(n+m)} \int_0^{2\pi} V_m^2 \sin^2 \omega t \, d(\omega t) \right]^{\frac{1}{2}}$$

$$V_{\alpha(RMS)} = \frac{V_m}{\sqrt{2}} \sqrt{\frac{n}{(m+n)}} = V_{i(RMS)} \sqrt{k} = V_S \sqrt{k}$$

$$V_{\alpha(RMS)} = V_{i(RMS)} \sqrt{k} = V_S \sqrt{k}$$

Where $V_S = V_{i(RMS)}$ = RMS value of input supply voltage.

- Duty Cycle

$$k = \frac{t_{ON}}{T_o} = \frac{t_{ON}}{(t_{ON} + t_{OFF})} = \frac{nT}{(m+n)T}$$

Where, $k = \frac{n}{(m+n)}$ = duty cycle (d).

- RMS Load Current

$$I_{\alpha(RMS)} = \frac{V_{\alpha(RMS)}}{Z} = \frac{V_{\alpha(RMS)}}{R_L}; \quad \text{for a resistive load } Z = R_L.$$

- Output AC (Load) Power

$$P_O = I_{\alpha(RMS)}^2 \times R_L$$

- Input Power Factor

$$PF = \frac{P_O}{VA} = \frac{\text{output load power}}{\text{input supply volt amperes}} = \frac{P_O}{V_S I_S}$$

$$PF = \frac{I_{\alpha(RMS)}^2 \times R_L}{V_{i(RMS)} \times I_{m(RMS)}}; \quad I_S = I_{m(RMS)} = \text{RMS input supply current}$$

The input supply current is same as the load current $I_m = I_O = I_L$

Hence, RMS supply current = RMS load current; $I_{m(RMS)} = I_{\alpha(RMS)}$

$$PF = \frac{I_{\alpha(RMS)}^2 \times R_L}{V_{i(RMS)} \times I_{m(RMS)}} = \frac{V_{\alpha(RMS)}}{V_{i(RMS)}} = \frac{V_{i(RMS)} \sqrt{k}}{V_{i(RMS)}} = \sqrt{k}$$

$$PF = \sqrt{k} = \sqrt{\frac{n}{m+n}}$$

Applications of ac voltage controllers

- Lighting / Illumination control in ac power circuits.
- Induction heating.
- Industrial heating & Domestic heating.
- Transformers tap changing (on load transformer tap changing).
- Speed control of induction motors (single phase and poly phase ac induction motor control).
- AC magnet controls.

5.3.1 Single phase AC voltage controller with R load

AC to AC voltage converters operate on the AC mains essentially to regulate the output voltage. Portions of the supply sinusoid appear at the load while the semiconductor switches block the remaining portions. Several topologies have emerged along with voltage regulation methods, most of which are linked to the development of the semiconductor devices.

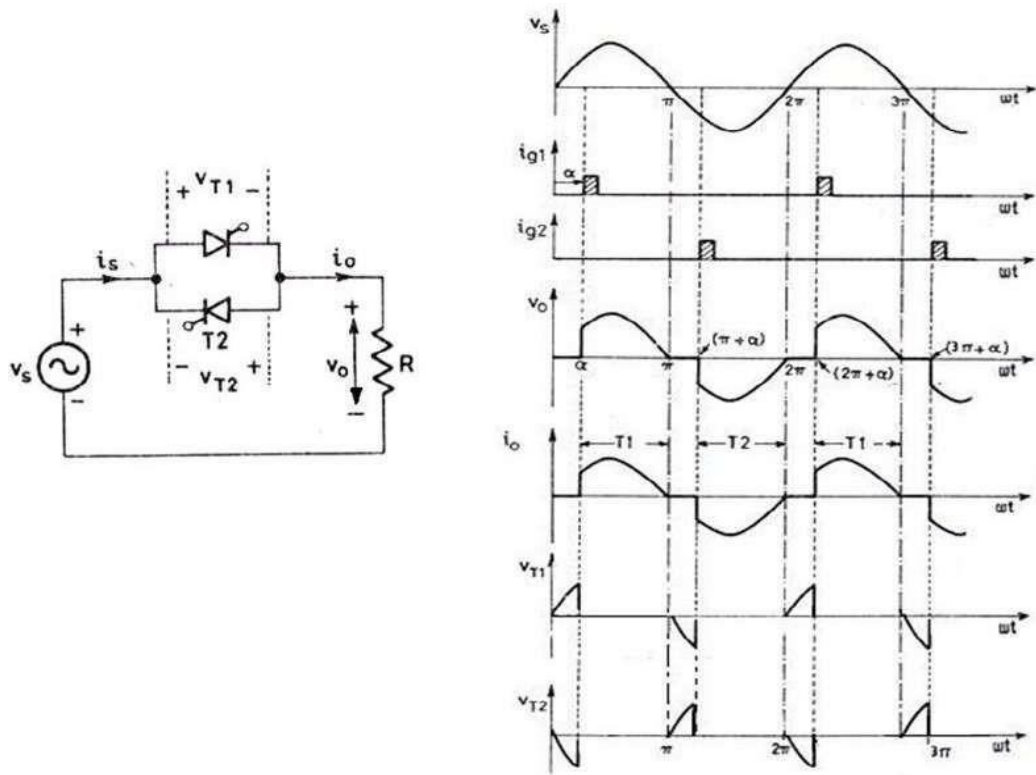

Figure: 3.2 Circuit diagram and output waveforms of AC voltage controller with R load

Fig. 2.35 illustrates the operation of the PAC converter with a resistive load. The device(s) is triggered at a phase-angle ' α ' in each cycle. The current follows the voltage wave shape in each half and extinguishes itself at the zero crossings of the supply voltage. In the two-SCR topology, one SCR is positively biased in each half of the supply voltage. There is no scope for conduction overlap of the devices. A single pulse is sufficient to trigger the controlled devices with a resistive load. In the diode-SCR topology, two diodes are forward biased in each half. The SCR always receives a DC voltage and does not distinguish the polarity of the supply. It is thus always forward biased. The bi-directional TRIAC is also forward biased for both polarities of the supply voltage.

The rms voltage V_{rms} decides the power supplied to the load. It can be computed as

$$V_{rms} = \sqrt{\frac{1}{\pi} \int_{\alpha}^{\pi} 2V^2 \sin^2 \omega t \, d\omega t}$$

$$= V \sqrt{1 - \frac{\alpha}{\pi} + \frac{\sin 2\alpha}{2\pi}}$$

Power Factor

The power factor of a nonlinear deserves a special discussion. Fig. 2.35 shows the supply voltage and the non-sinusoidal load current. The fundamental load/supply current lags the supply voltage by the ϕ_1 , 'Fundamental Power Factor' angle. $\cos\phi_1$ is also called the 'Displacement Factor'. However this does not account for the total reactive power drawn by the system. This power factor is in spite of the actual load being resistive! The reactive power is drawn also by the trigger-angle dependent harmonics. Now

$$\text{power factor} = \frac{\text{average power}}{\text{apparent voltamperes}} = \frac{P}{VI_L}$$

$$= \frac{VI_{L1} \cos \phi_1}{VI_L}$$

$$\text{distortion factor} = \frac{I_{L1}}{I_L}$$

The Average Power, P drawn by the resistive load is

$$P = \frac{1}{2\pi} \int_0^{2\pi} v i_L \, d\omega t = \frac{1}{\pi} \int_{\alpha}^{\pi} \frac{2V^2}{R} \sin^2 \omega t \, d\omega t$$

$$= \frac{2V^2}{R\pi} \left[\pi - \frac{\alpha}{2} + \frac{\sin 2\alpha}{2} \right]$$

5.3.2 Single phase AC voltage controller with RL load

With inductive loads the operation of the PAC is illustrated in Fig 2. 36. The current builds up from zero in each cycle. It quenches not at the zero crossing of the applied voltage as with the resistive load but after that instant. The supply voltage thus continues to be impressed on the load till the load current returns to zero. A single-pulse trigger for the TRIAC) or the anti parallel SCR has no effect on the devices if it (or the anti-parallel device) is already in conduction in the reverse direction. The devices would fail to conduct when they are intended to, as they do not have the supply voltage forward biasing them when the trigger pulse arrives. A single pulse trigger will work till the trigger angle $\alpha > \phi$, where ϕ is the power factor angle of the inductive load. A train of pulses is required here. The output voltage is controllable only between triggering angles ϕ and 180° . The load current waveform is further explained in Fig. 26.6. The current is composed of two components. The first is the steady state component of the load current, i_{ss} and the second, i_{tr} is the transient component.

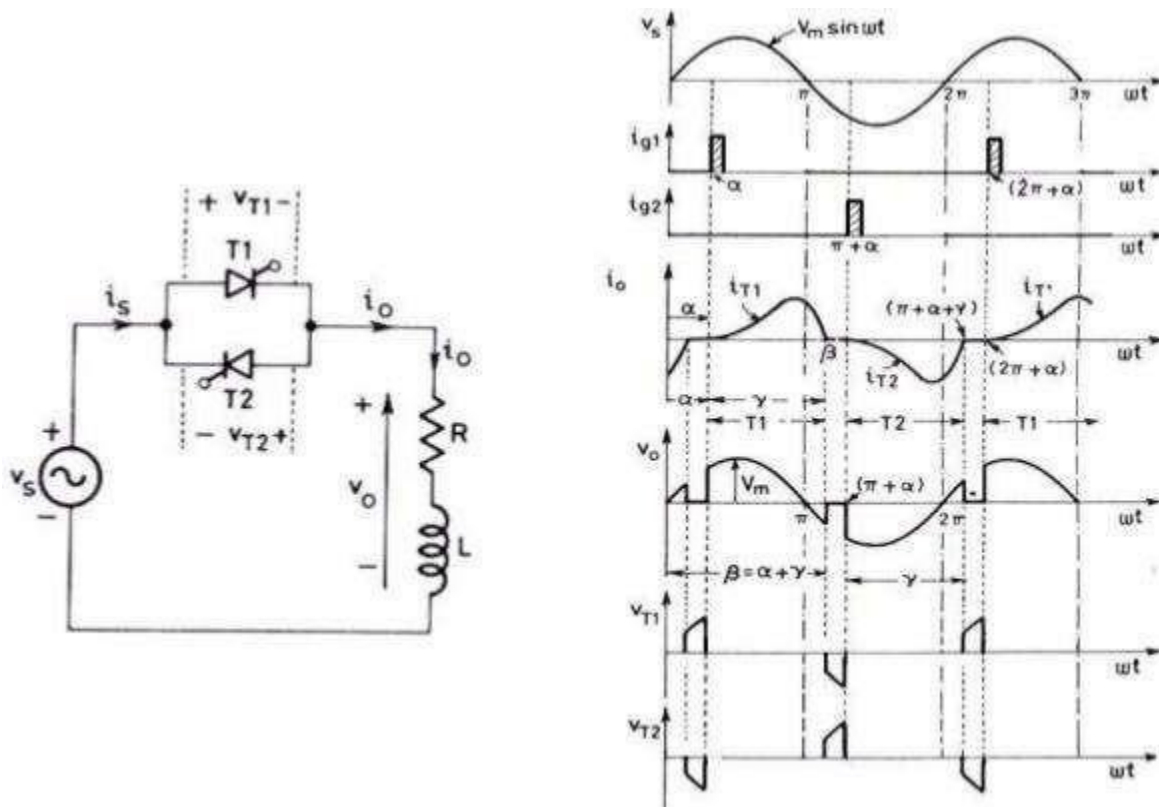

Figure: 3.3 Circuit diagram and output waveforms of AC voltage controller with RL load

With an inductance in the load the distinguishing feature of the load current is that it must always start from zero. However, if the switch could have permanently kept the load connected to the supply the current would have become a sinusoidal one phase shifted from the voltage by the phase angle of the load, ϕ . This current restricted to the half periods of conduction is called the 'steady-state component' of load current. The 'transient component' of load current i_{tr} , again in each half cycle, must add up to zero with this i_{ss} to start from zero. This condition sets the initial value of the transient component to that of the steady state at the instant that the SCR/TRIAC is triggered. Fig. 2. 36 illustrates these relations. When a device is in conduction, the load current is governed by the equation

$$L \frac{di}{dt} + Ri = v_s$$

$$i_{load} = \frac{\sqrt{2}V}{Z} \left[\sin(\omega t - \phi) + \sin(\alpha - \phi) e^{-\frac{R}{L}(\frac{\omega}{\omega} - t)} \right]$$

Since at $t = 0$, $i_{load} = 0$ and supply voltage $v_s = \sqrt{2}V \sin \omega t$ the solution is of the form the instant when the load current extinguishes is called the extinction angle β . It can be inferred that there would be no

transients in the load current if the devices are triggered at the power factor angle of the load. The load current I that case is perfectly sinusoidal.

Modes of operation of TRIAC

The triac is an important member of the thyristor family of devices. It is a bidirectional device that can pass the current in both forward and reverse biased conditions and hence it is an AC control device. The triac is equivalent to two back to back SCRs connected with one gate terminal as shown in figure. The triac is an abbreviation for a TRIode AC switch. TRI means that the device consisting of three terminals and AC means that it controls the AC power or it can conduct in both directions of alternating current.

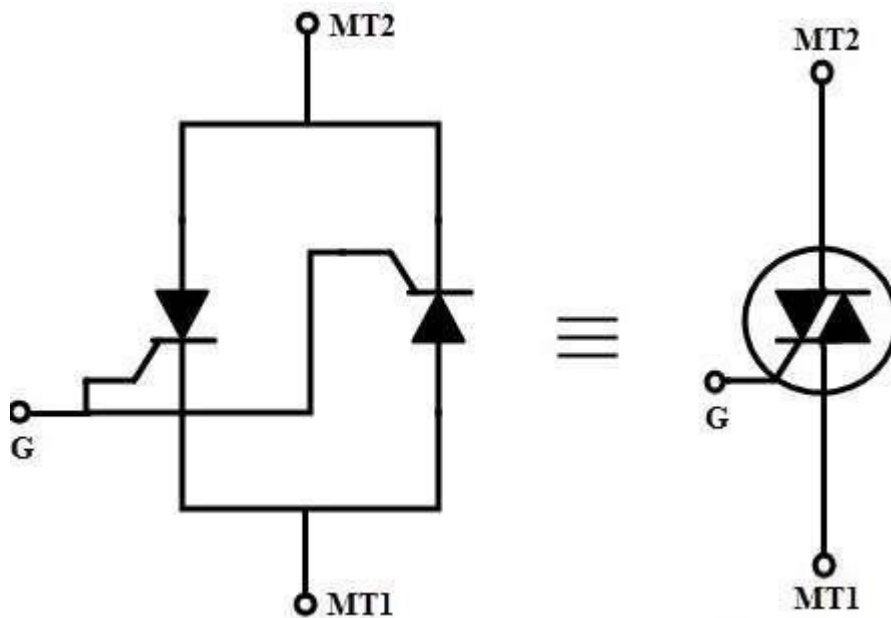

Figure: 3.4 Two thyristor analogy and circuit symbol of TRIAC

The triac has three terminals namely Main Terminal 1 (MT1), Main Terminal 2 (MT2) and Gate (G) as shown in figure. If MT1 is forward biased with respect to MT2, then the current flows from MT1 to MT2. Similarly, if the MT2 is forward biased with respect to MT1, then the current flows from MT2 to MT1. The above two conditions are achieved whenever the gate is triggered with an appropriate gate pulse. Similar to the SCR, triac is also turned by injecting appropriate current pulses into the gate terminal. Once it is turned ON, it loses its gate control over its conduction. So triac can be turned OFF by reducing the current to zero through the main terminals.

Construction of TRIAC

A triac is a five layer, three terminal semiconductor device. The terminals are marked as MT1, MT2 as anode and cathode terminals in case of SCR. And the gate is represented as G similar to the thyristor. The gate terminal is connected to both N4 and P2 regions by a metallic contact and it is near to the MT1 terminal. The terminal MT1 is connected to both N2 and P2 regions, while MT2 is connected to both N3 and P1 regions. Hence, the terminals MT1 and MT2 connected to both P and N regions of the device and thus the polarity of applied voltage between these two terminals decides the current flow through the layers of the device.

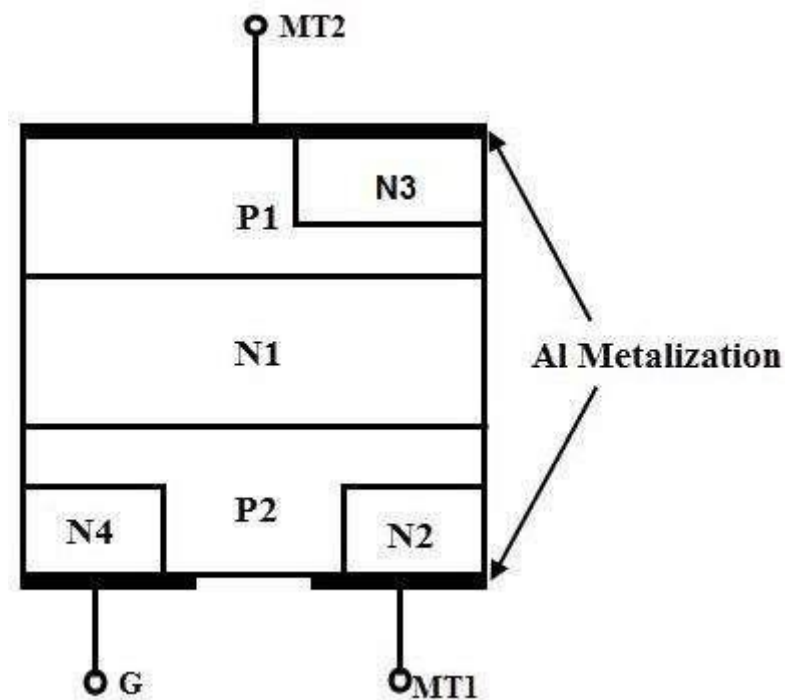

Figure: 3.5 construction of TRIAC

With the gate open, MT2 is made positive with respect to MT1 for a forward biased triac. Hence triac operates in forward blocking mode until the voltage across the triac is less than the forward break over voltage. Similarly for a reverse biased triac, MT2 is made negative with respect to MT1 with gate open. Until the voltage across the triac is less than the reverse break over voltage, device operates in a reverse blocking mode. A triac can be made conductive by either positive or negative voltage at the gate terminal.

Working and Operation of TRIAC

It is possible to connect various combinations of negative and positive voltages to the triac terminals because it is a bidirectional device. The four possible electrode potential combinations which make the triac to operate four different operating quadrants or modes are given as.

1. MT2 is positive with respect to MT1 with a gate polarity positive with respect to MT1.
2. MT2 is positive with respect to MT1 with a gate polarity negative with respect to MT1.
3. MT2 is negative with respect to MT1 with a gate polarity negative with respect to MT1.
4. MT2 is negative with respect to MT1 with a gate polarity positive with respect to MT1.

In general, latching current is higher in second quadrant or mode whilst gate trigger current is higher in the fourth mode compared with other modes for any triac. Most of the applications, negative triggering current circuit is used that means 2 and 3 quadrants are used for a reliable triggering in bidirectional control and also when the gate sensitivity is critical. The gate sensitivity is highest with modes 1 and 4 are generally employed.

Mode 1: MT2 is Positive, Positive Gate Current

When the gate terminal is made positive with respect to MT1, gate current flows through the P2 and N2 junction. When this current flows, the P2 layer is flooded with electrons and further these electrons are diffused to the edge of junction J2 (or P2-N1 junction). These electrons collected by the N1 layer builds a space charge on the N1 layer. Therefore, more holes from the P1 region are diffused into the N1 region to neutralize the negative space charges. These holes arrive at the junction J2 and produce the positive space charge in the P2 region, which causes more electrons to inject into P2 from N2. This results a positive regeneration and finally the main current flows from MT2 to MT1 through the regions P1- N1 – P2 – N2.

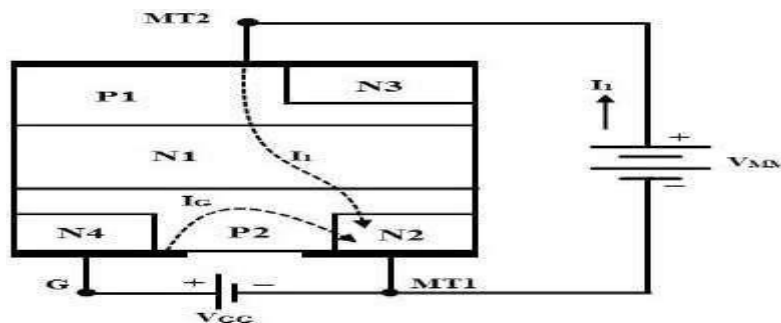

Figure: 3.6 Mode 1 operation of TRIAC

Mode 2: MT2 is Positive, Negative Gate Current

When MT2 is positive and the gate terminal is negative with respect to MT1, gate current flows through the P2-N4 junction. This gate current forward biases the P2-N4 junction for auxiliary P1N1P2N4 structure. This results the triac to conduct initially through the P1N1P2N4 layers. This further raises the potential between P2N2 towards the potential of MT2. This causes the current to establish from left to right in the P2 layer which forward biases the junction P2N2. And hence the main structure P1N1P2N2 begins to conduct. Initially conducted auxiliary structure P1N1P2N4 is considered as a pilot SCR while later conducted structure P1N1P2N2 is considered as main SCR. Hence the anode current of pilot SCR serves as gate current to the main SCR. The sensitivity to gate current is less in this mode and hence more gate current is required to turn the triac.

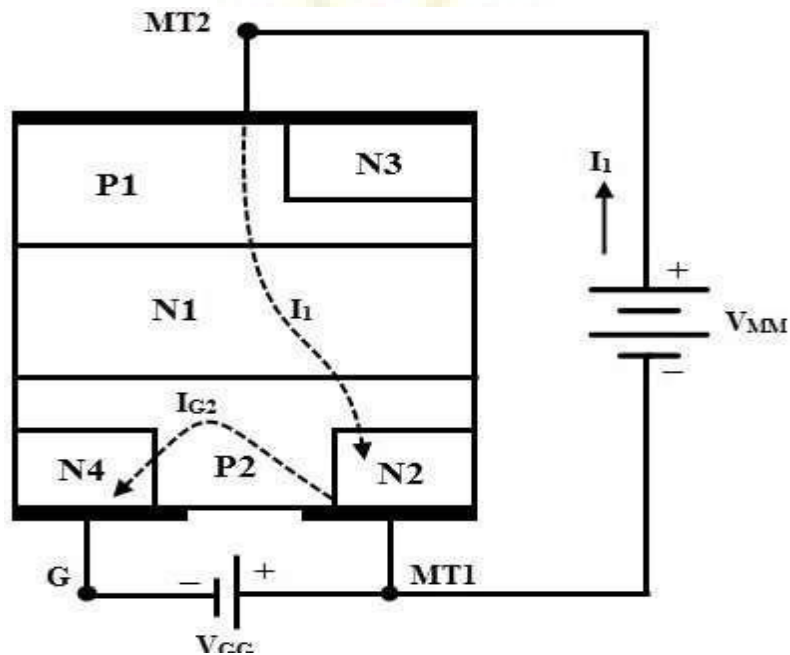

Figure: 3.7 Mode 2 operation of TRIAC

Mode 3: MT2 is Negative, Positive Gate Current

In this mode, MT2 is made negative with respect to MT1 and the device is turned ON by applying a positive voltage between the gate and MT1 terminal. The turn ON is initiated by N2 which acts as a remote gate control and the structure leads to turn ON the triac is P2N1P1N3. The external gate current forward biases the junction P2-N2. N2 layer injects the electrons into the P2 layer which are then collected by junction P2N1. This result to increases the current flow through P2N1 junction.

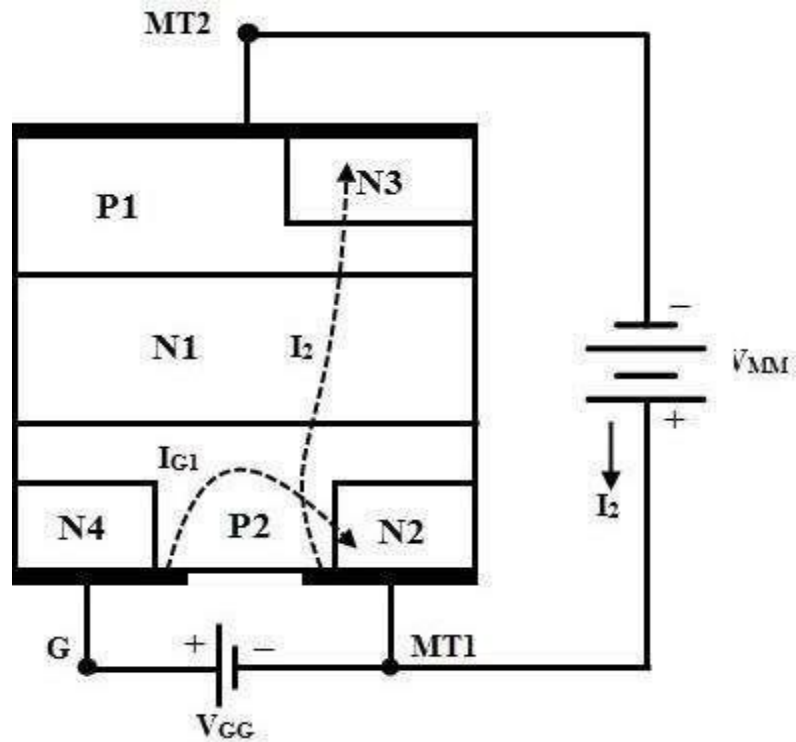

Figure: 3.8 Mode 3 operation of TRIAC

The holes injected from layer P2 diffuse through the N1 region. This builds a positive space charge in the P region. Therefore, more electrons from N3 are diffused into P1 to neutralize the positive space charges. Hence, these electrons arrive at junction J2 and produce a negative space charge in the N1 region which results to inject more holes from the P2 into the region N1. This regenerative process continues till the structure P2N1P1N3 turns ON the triac and conducts the external current. As the triac is turned ON by the remote gate N2, the device is less sensitive to the positive gate current in this mode.

Mode 4: MT2 is Negative, Negative Gate Current

In this mode N4 acts as a remote gate and injects the electrons into the P2 region. The external gate current forward biases the junction P2N4. The electrons from the N4 region are collected by the P2N1 junction increase the current across P1N1 junction. Hence the structure P2N1P1N3 turns ON by the regenerative action. The triac is more sensitive in this mode compared with positive gate current in mode 3.

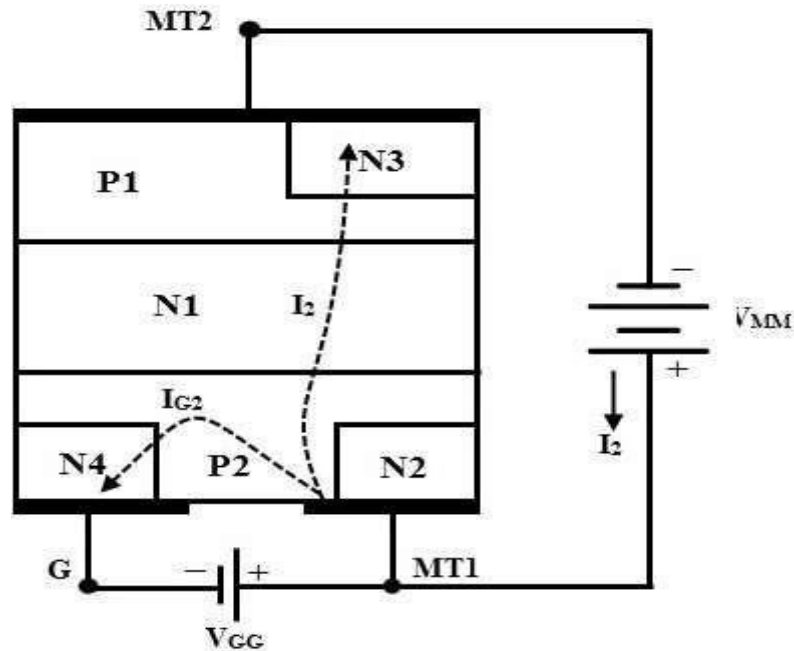

Figure: 3.9 Mode 4 operation of TRIAC

From the above discussion, it is concluded that the modes 2 and 3 are less sensitive configuration which needs more gate current to trigger the triac, whereas more common triggering modes of triac are 1 and 4 which have greater sensitivity. In practice the more sensitive mode of operation is selected such that the polarity of the gate is to match with the polarity of the terminal MT2.

V-I Characteristics of TRIAC:

The triac function like a two thyristors connected in anti-parallel and hence the VI characteristics of triac in the 1st and 3rd quadrants will be similar to the VI characteristics of a thyristors. When the terminal MT2 is positive with respect to MT1 terminal, the triac is said to be in forward blocking mode. A small leakage current flows through the device provided that voltage across the device is lower than the breakover voltage. Once the breakover voltage of the device is reached, then the triac turns ON as shown in below figure. However, it is also possible to turn ON the triac below the VBO by applying a gate pulse in such that the current through the device should be more than the latching current of the triac.

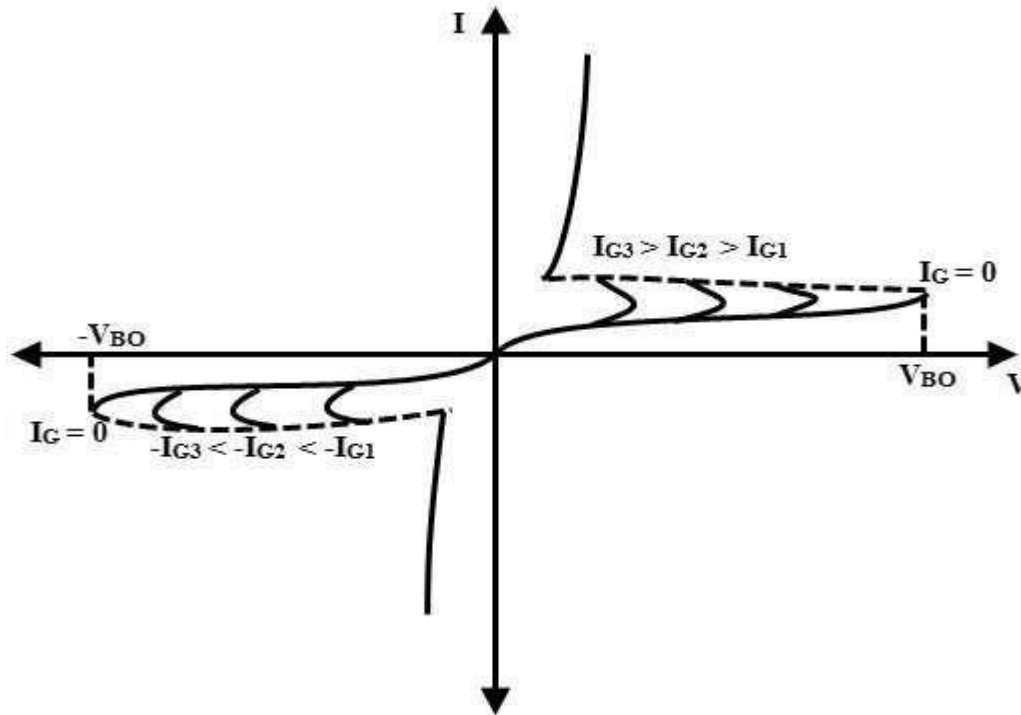

Figure: 3.10 V-I characteristics of TRIAC

Similarly, when the terminal MT2 is made negative with respect to MT1, the triac is in reverse blocking mode. A small leakage current flows through the device until it is triggered by breakover voltage or gate triggering method. Hence the positive or negative pulse to the gate triggers the triac in both directions. The supply voltage at which the triac starts conducting depends on the gate current. If the gate current is being greater, lesser will be the supply voltage at which the triac is turned ON. Above discussed mode - 1 triggering is used in the first quadrant whereas mode-3 triggering is used in 3rd quadrant. Due to the internal structure of the triac, the actual values of latching current, gate trigger current and holding current may be slightly different in different operating modes. Therefore, the ratings of the triacs considerably lower than the thyristors.

Advantages of TRIAC

Triac can be triggered by both positive and negative polarity voltages applied at the gate.

- It can operate and switch both half cycles of an AC waveform.
- As compared with the anti-parallel thyristor configuration which requires two heat sinks of slightly smaller size, a triac needs a single heat sink of slightly larger size. Hence the triac saves both space and cost in AC power applications.

- In DC applications, SCRs are required to be connected with a parallel diode to protect against reverse voltage. But the triac may work without a diode, a safe breakdown is possible in either direction.

Disadvantages of TRIAC

- These are available in lower ratings as compared with thyristors.
- A careful consideration is required while selecting a gate trigger circuit since a triac can be triggered in both forward and reverse biased conditions.
- These have low dv/dt rating as compared with thyristors.
- These have very small switching frequencies.
- Triacs are less reliable than thyristors.

Numerical Problems

1. A single phase voltage controller is employed for controlling the power flow from 230V, 50Hz source into a load circuit consisting of $R=3\ \Omega$ and $\omega L=4\ \Omega$. Calculate

- (i) the range of firing angle
- (ii) the maximum value of rms load current
- (iii) the maximum power and power factor
- (iv) The maximum values of average and rms thyristor currents.

Solution:

- i. For controlling the load the minimum value of firing angle $\alpha =$ load phase angle

$$\varphi = \tan^{-1} \frac{\omega L}{R} = \tan^{-1} \frac{4}{3} = 53.13^\circ$$

The maximum possible value of α is 180°

So the firing angle control range is $53.13^\circ \leq \alpha \leq 180^\circ$

- ii. The maximum value of rms value of load current occurs when $\alpha = \Phi = 53.13^\circ$

But at this value of firing angle, the power circuit of ac voltage controller behaves as if load is directly connected to ac source. Therefore maximum value of rms load current is

$$I_0 = \frac{230}{\sqrt{R^2 + (wL)^2}} = \frac{230}{\sqrt{3^2 + 4^2}} = 46A$$

iii. Maximum power = $I_0^2 \times R = 46^2 \times 3 = 6348W$

$$\text{Power factor} = \frac{I_0^2 \times R}{V_{slo} \times 230} = \frac{46 \times 3}{230} = 0.6$$

iv. Average thyristor current is maximum when $\alpha = \Phi$ and conduction angle $\gamma = M$

$$I_{TAVG} = \frac{1}{2\pi} \int_{\alpha}^{\alpha+\pi} \frac{V_m}{Z} \sin(\omega t - \varphi) d(\omega t)$$

$$= \frac{V_m}{\pi Z} = \frac{\sqrt{2} \times 230}{\pi \times \sqrt{3^2 + 4^2}} = 20.707A$$

Similarly maximum value of thyristor current is

$$I_{T_{rms}} = \left\{ \frac{1}{2\pi} \int_{\alpha}^{\alpha+\pi} \frac{V_m^2}{Z^2} \sin^2(\omega t - \alpha) d(\omega t) \right\}^{1/2}$$

$$= \frac{V_m}{2Z} = \frac{\sqrt{2} \times 230}{2 \times \sqrt{3^2 + 4^2}} = 32.527A$$

2. An ac voltage controller uses a TRIAC for phase angle control of a resistive load of 100Ω . Calculate the value of delay angle for having an rms load voltage of 220 volts. Also calculate the rms value of TRIAC current. Assume the rms supply voltage to be 230V.

3. The ac voltage controller uses on-off control for heating a resistive load of $R = 4$ ohms and the input voltage is $V_s = 208V$, 60Hz. If the desired output power is $P_o = 3KW$, determine the

(a) duty cycle δ

(b) input power factor

Sketch waveforms for the duty cycle obtained in (a)

5.4 Introduction to Cyclo converters

The Cycloconverter has been traditionally used only in very high power drives, usually above one megawatt, where no other type of drive can be used. Examples are cement tube mill drives above 5 MW, the 13 MW German-Dutch wind tunnel fan drive, reversible rolling mill drives and ship propulsion drives. The reasons for this are that the traditional Cycloconverter requires a large number of thyristors, at least 36 and usually more for good motor performance, together with a very complex control circuit, and it has some performance limitations, the worst of which is an output frequency limited to about one third the input frequency .

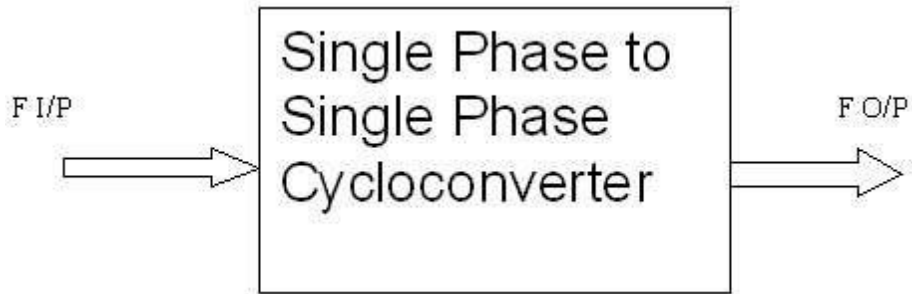

Figure 3.11 Block diagram of cycloconverters

The Cycloconverter has four thyristors divided into a positive and negative bank of two thyristors each. When positive current flows in the load, the output voltage is controlled by phase control of the two positive bank thyristors whilst the negative bank thyristors are kept off and vice versa when negative current flows in the load. An idealized output waveform for a sinusoidal load current and a 45 degrees load phase angle is shown in Figure 3.11. It is important to keep the non conducting thyristor bank off at all times, otherwise the mains could be shorted via the two thyristor banks, resulting in waveform distortion and possible device failure from the shorting current. A major control problem of the Cycloconverter is how to swap between banks in the shortest possible time to avoid distortion whilst ensuring the two banks do not conduct at the same time. A common addition to the power circuit that removes the requirement to keep one bank off is to place a centre tapped inductor called a circulating current inductor between the outputs of the two banks. Both banks can now conduct together without shorting the mains. Also, the circulating current in the inductor keeps both banks operating all the time, resulting in improved output waveforms. This technique is not often used, though, because the circulating current inductor tends to be expensive and bulky and the circulating current reduces the power factor on the input

In a 1- ϕ Cycloconverter, the output frequency is less than the supply frequency. These converters require natural commutation which is provided by AC supply. During positive half cycle of supply, Thyristors P1 and N2 are forward biased. First triggering pulse is applied to P1 and hence it starts conducting.

As the supply goes negative, P1 gets off and in negative half cycle of supply, P2 and N1 are forward biased. P2 is triggered and hence it conducts. In the next cycle of supply, N2 in positive half cycle and N1 in negative half cycle are triggered. Thus, we can observe that here the output frequency is 1/2 times the supply frequency.

Operation Principles

The following sections will describe the operation principles of the Cycloconverter starting from the simplest one, single-phase to single-phase (1f-1f) Cycloconverter.

Single-phase to Single-phase (1 Φ -1 Φ) Cycloconverter

To understand the operation principles of **Cycloconverters**, the single-phase to single-phase Cycloconverter (Fig. 3.12) should be studied first. This converter consists of back-to-back connection of two full-wave rectifier circuits. Fig 3.13 shows the operating waveforms for this converter with a resistive load.

Zero Firing angle, i.e. thyristors act like diodes. Note that the firing angles are named as α_P for the positive converter and α_N for the negative converter. The input voltage, v_s is an ac voltage at a frequency, f_i as shown in Fig. 3.13. For easy understanding assume that all the thyristors are fired at $\alpha=0^\circ$

Consider the operation of the Cycloconverter to get one-fourth of the input frequency at the output. For the first two cycles of v_s , the positive converter operates supplying current to the load. It rectifies the input voltage; therefore, the load sees 4 positive half cycles as seen in Fig.

3.13. In the next two cycles, the negative converter operates supplying current to the load in the reverse direction. The current waveforms are not shown in the figures because the resistive load current will have the same waveform as the voltage but only scaled by the resistance. Note that when one of the converters operates the other one is disabled, so that there is no current circulating between the two rectifiers.

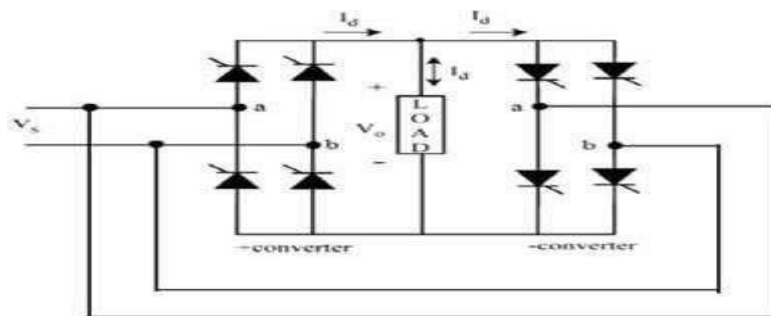

Figure 3.12 circuit diagram of cycloconverter

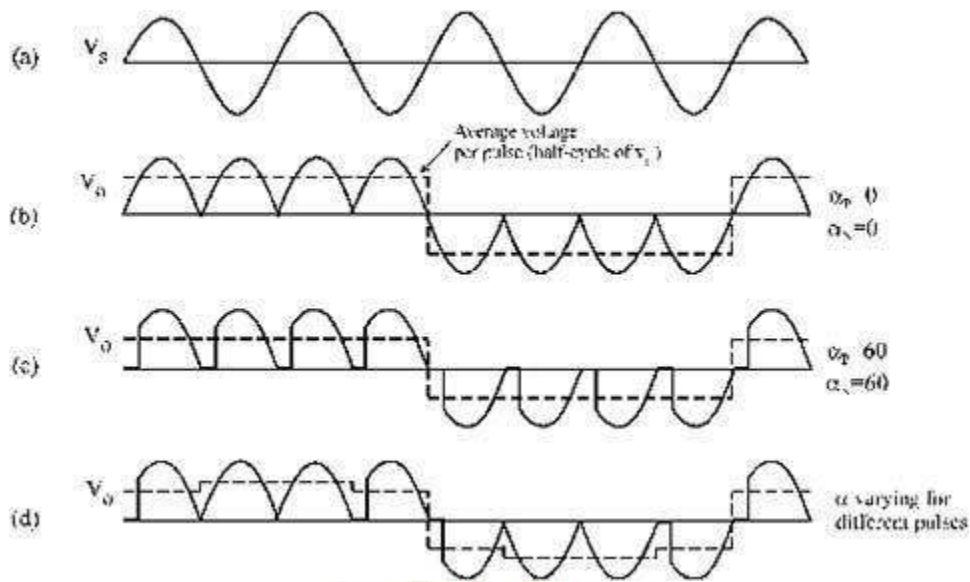

Figure 3.13 Input and output waveforms of cycloconverter

5.4.1 Single phase midpoint Cyclo converters

Basically, these are divided into two main types, and are given below

Step-down cyclo-converter

It acts like a step-down transformer that provides the output frequency less than that of input, $f_o < f_i$.

Step-up cyclo-converter

It provides the output frequency more than that of input, $f_o > f_i$.

In case of step-down cyclo-converter, the output frequency is limited to a fraction of input frequency, typically it is below 20Hz in case 50Hz supply frequency. In this case, no separate commutation circuits are needed as SCRs are line commutated devices.

But in case of step-up cyclo-converter, forced commutation circuits are needed to turn OFF SCRs at desired frequency. Such circuits are relatively very complex. Therefore, majority of cyclo-converters are of step-down type that lowers the frequency than input frequency.

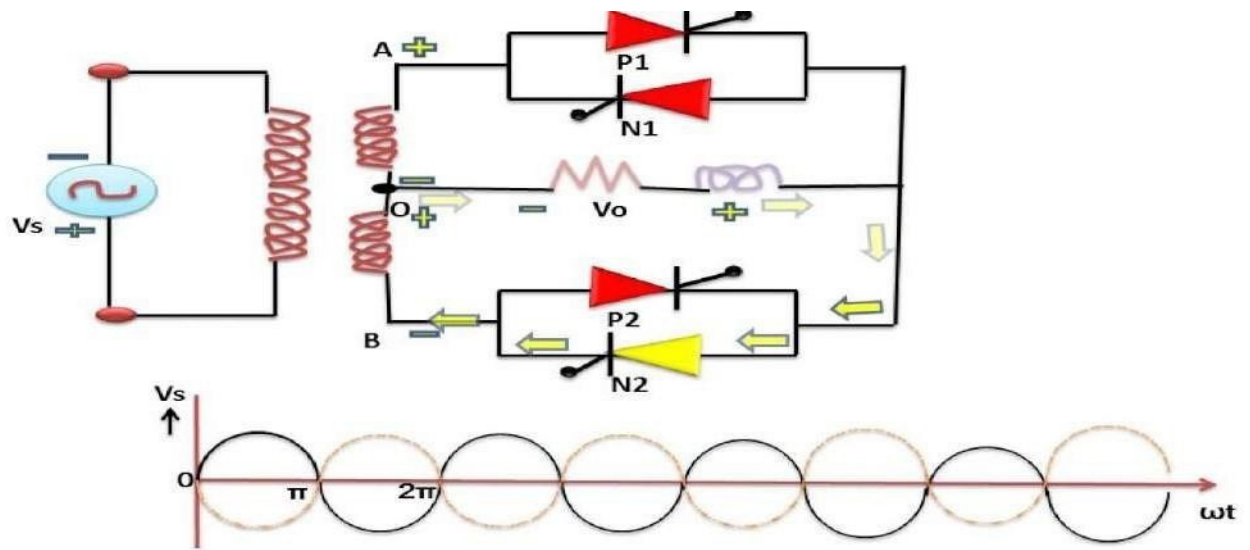

Figure 3.14 circuit diagram of midpoint cycloconverter

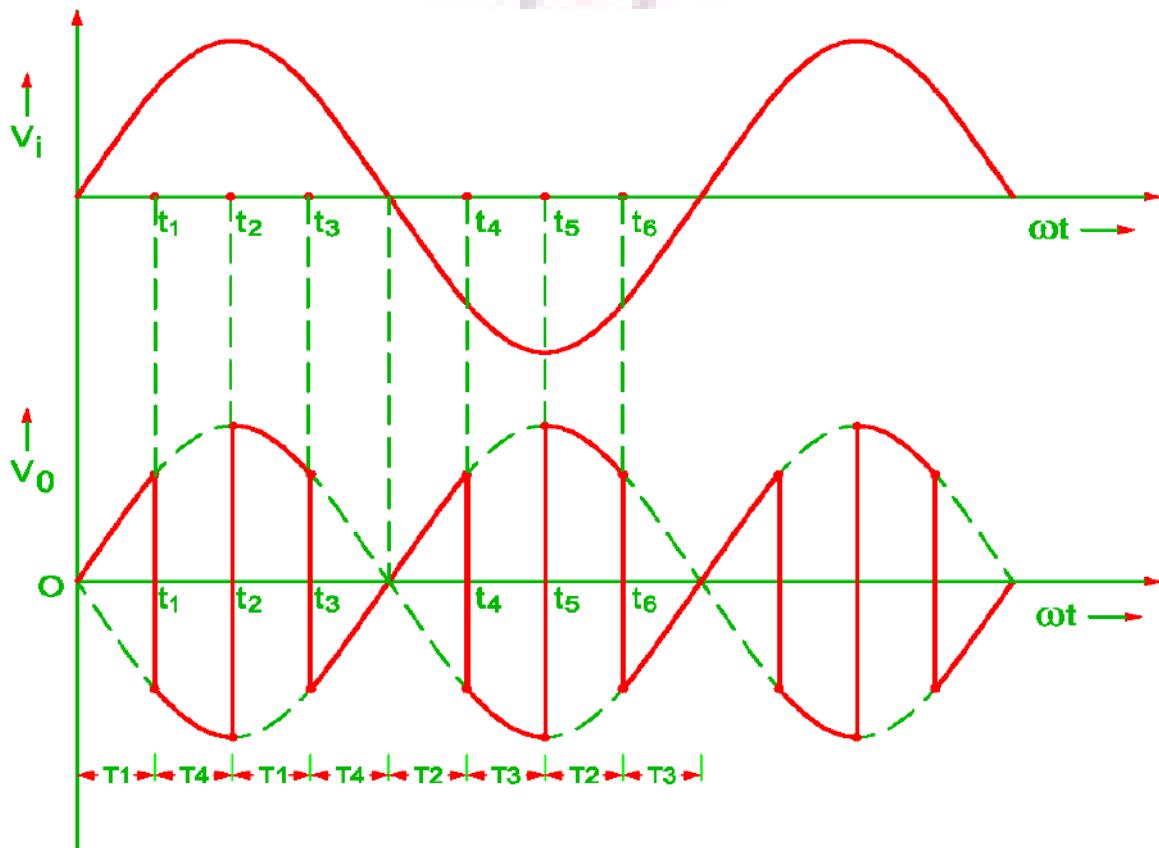

Figure 3.15 Input and output waveforms of midpoint cycloconverter

It consists of single phase transformer with mid tap on the secondary winding and four thyristors. Two of these thyristors P1, P2 are for positive group and the other two N1, N2 are for the negative group. Load is connected between secondary winding midpoint 0 and the load terminal. Positive directions for output voltage and output current are marked in figure 3.14

In figure 3.14 during the positive half cycle of supply voltage terminal a is positive with respect to terminal b. therefore in this positive half cycle, both p1 and N2 are forward biased from $\omega t = 0$ to Π . As such SCR P1 is turned on at $\omega t = 0$ so that load voltage is positive with terminal A and 0 negative. Now the load voltage is positive. At instant t_1 P1 is force commutated and forward biased thyristor N2 is turned on so that load voltage is negative with terminal 0 and A negative. Now the load voltage is negative. Now N2 is force commutated and P1 is turned on the load voltage is positive this is a continuous process and will get step up cyclo converter output

Bridge configuration of single phase Cyclo converter

The equivalent circuit of a cyclo-converter is shown in figure below. Here each two quadrant phase controlled converter is represented by a voltage source of desired frequency and consider that the output power is generated by the alternating current and voltage at desired frequency.

The diodes connected in series with each voltage source represent the unidirectional conduction of each two quadrant converter. If the output voltage ripples of each converter are neglected, then it becomes ideal and represents the desired output voltage.

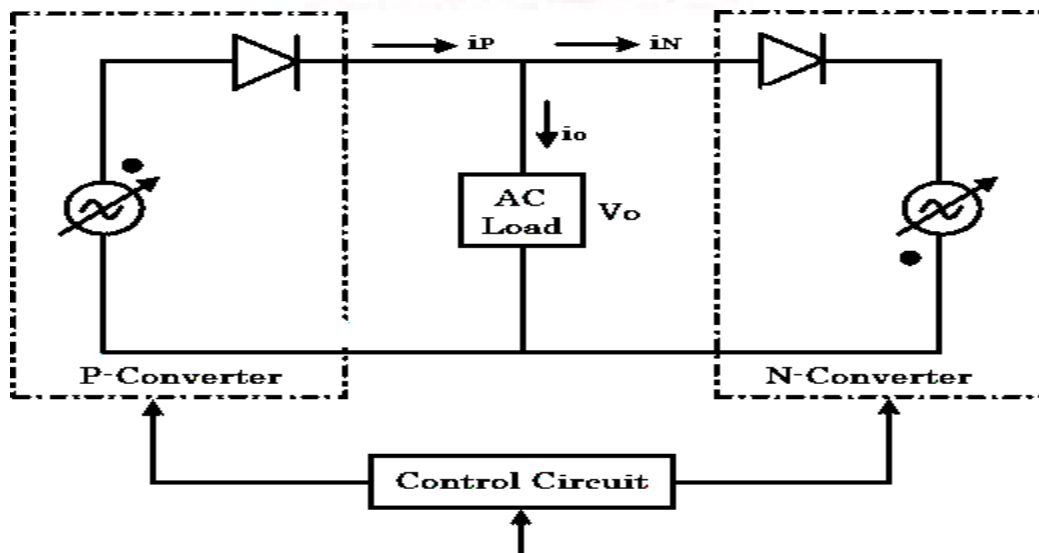

Figure 3.16 Block diagram of bridge type cycloconverter

If the firing angles of individual converters are modulated continuously, each converter produces same sinusoidal voltages at its output terminals.

So the voltages produced by these two converters have same phase, voltage and frequency. The average power produced by the cyclo-converter can flow either to or from the output terminals as the load current can flow freely to and from the load through the positive and negative converters.

Therefore, it is possible to operate the loads of any phase angle (or power factor), inductive or capacitive through the cyclo-converter circuit.

Due to the unidirectional property of load current for each converter, it is obvious that positive converter carries positive half-cycle of load current with negative converter remaining in idle during this period.

Similarly, negative converter carries negative half cycle of the load current with positive converter remaining in idle during this period, regardless of the phase of current with respect to voltage.

This means that each converter operates both in rectifying and inverting regions during the period of its associated half cycles.

The figure below shows ideal output current and voltage waveforms of a cyclo-converter for lagging and leading power factor loads. The conduction periods of positive and negative converters are also illustrated in the figure.

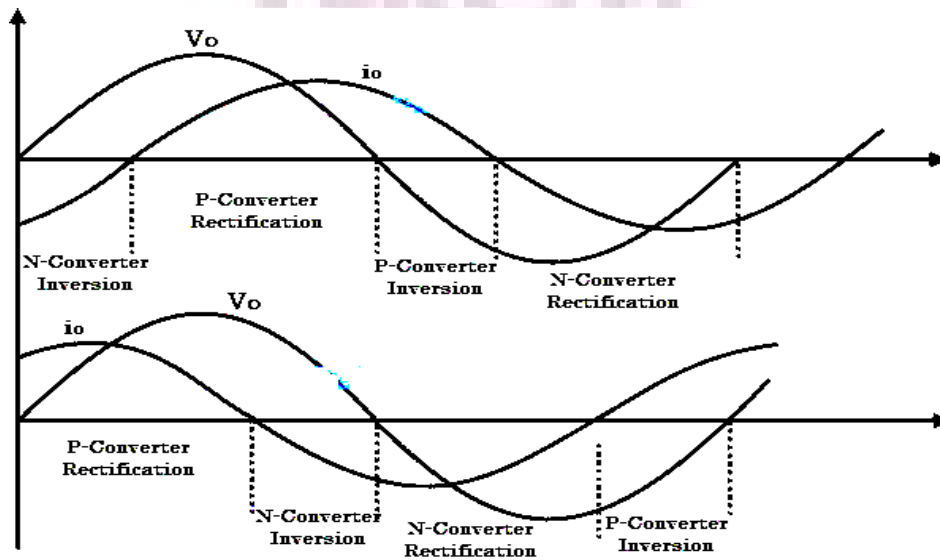

Figure 3.17 cycloconverter waveforms

The positive converter operates whenever the load current is positive with negative converter remaining in idle. In the same manner negative converter operates for negative half cycle of load current.

Both rectification and inversion modes of each converter are shown in figure. This desired output voltage is produced by regulating the firing angle to individual converters.

5.4.2 Single-phase to single-phase cyclo-converters

These are rarely used in practice; however, these are required to understand fundamental principle of cyclo-converters.

It consists of two full-wave, fully controlled bridge thyristors, where each bridge has 4 thyristors, and each bridge is connected in opposite direction (back to back) such that both positive and negative voltages can be obtained as shown in figure below. Both these bridges are excited by single phase, 50 Hz AC supply.

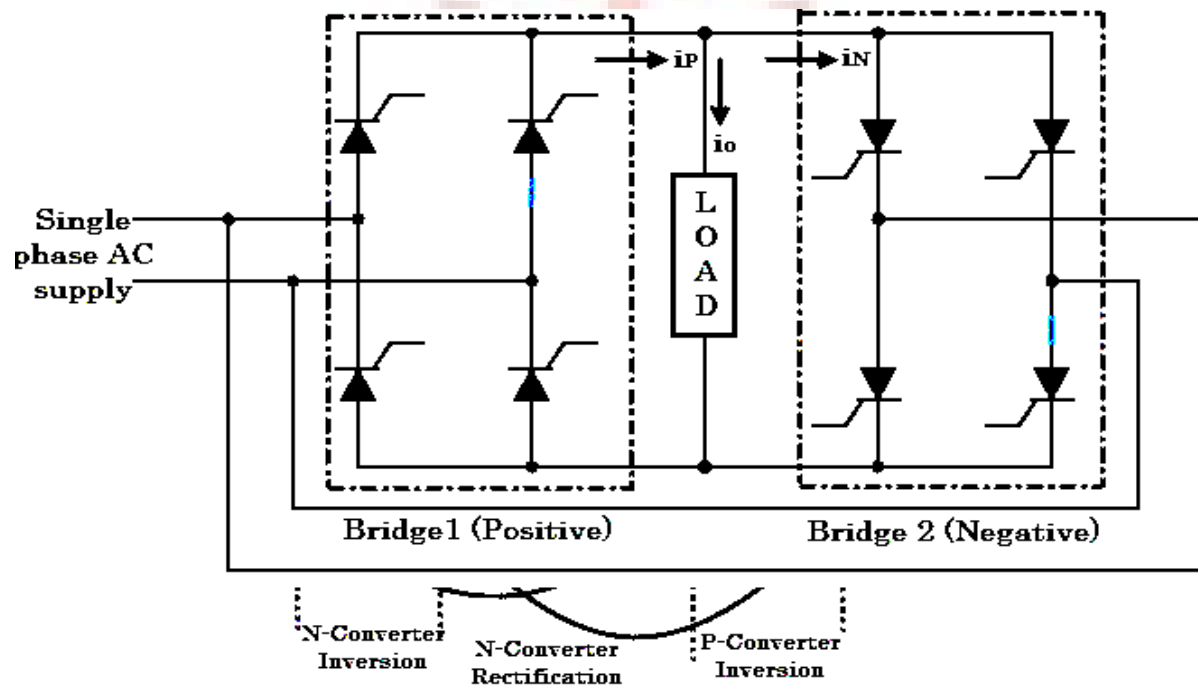

Figure 3.18 Circuit diagram of bridge type cycloconverter

During positive half cycle of the input voltage, positive converter (bridge-1) is turned ON and it supplies the load current. During negative half cycle of the input, negative bridge is turned ON and it supplies load current. Both converters should not conduct together that cause short circuit at the input.

To avoid this, triggering to thyristors of bridge-2 is inhibited during positive half cycle of load current, while triggering is applied to the thyristors of bridge-1 at their gates. During negative half cycle of load current, triggering to positive bridge is inhibited while applying triggering to negative bridge.

By controlling the switching period of thyristors, time periods of both positive and negative half cycles are changed and hence the frequency. This frequency of fundamental output voltage can be easily reduced in steps, i.e., 1/2, 1/3, 1/4 and so on.

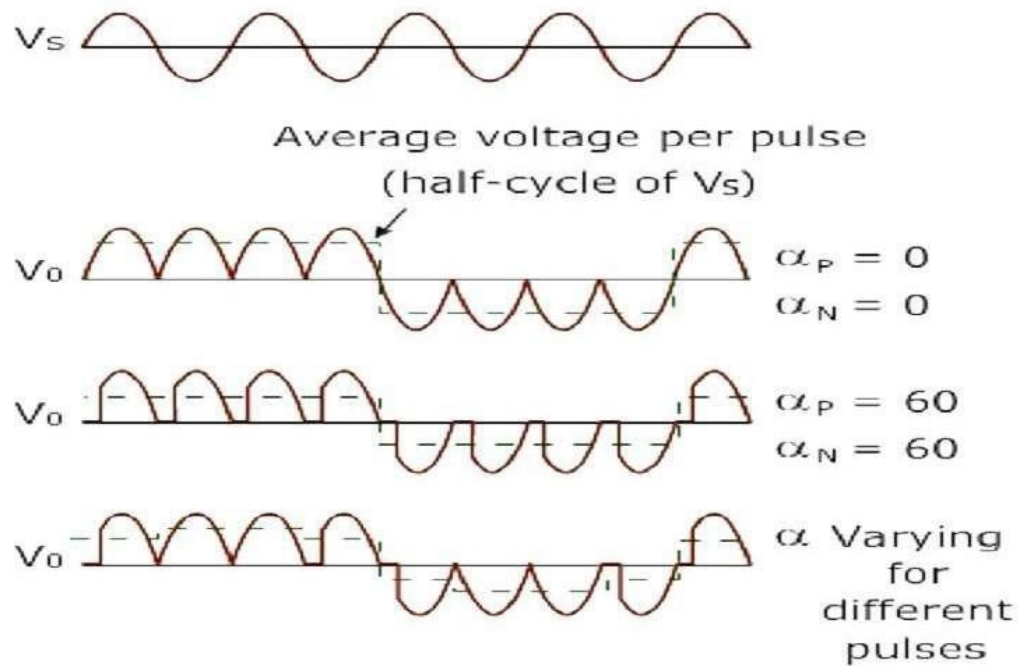

Figure 3.19 Input and output waveforms of bridge type cycloconverter

The above figure shows output waveforms of a cyclo-converter that produces one-fourth of the input frequency. Here, for the first two cycles, the positive converter operates and supplies current to the load.

It rectifies the input voltage and produce unidirectional output voltage as we can observe four positive half cycles in the figure. And during next two cycles, the negative converter operates and supplies load current.

Here current waveforms are not shown because it is a resistive load in where current (with less magnitude) exactly follows the voltage.

Here one converter is disabled if another one operates, so there is no circulating current between two converters. Since the discontinuous mode of control scheme is complicated, most cyclo-converters are

operates on circulating current mode where continuous current is allowed to flow between the converters with a reactor.

This circulating current type cyclo-converter can be operated on with both purely resistive (R) and inductive (R-L) loads.

Numerical Problems:

1. A single-phase to single-phase cycloconverter is supplying an inductive load comprising of a Resistance of 5Ω and an inductance of 40 mH from a 230 V , 50 Hz single-phase supply. It is required to provide an output frequency which is $1/3$ of the input frequency. If the converters are operated as semi-converter such that $0 \leq \alpha \leq \pi$ and firing delay angle is 120° . Neglecting the harmonic content of load voltage, determine:
 - (a) rms value of output voltage.
 - (b) rms current of each thyristor and
 - (c) input power factor.

Solution:

$$E = 230\text{ V}, f_1 = 50\text{ Hz}, \alpha_p = \frac{2\pi}{3}$$

$$f_0 = 50/2 = 16.2/3\text{ Hz}, R = 5\Omega, L = 40\text{ mH}$$

$$\omega_0 = 2\pi \times 50/3 = 104.72\text{ rad/s}$$

$$X_L = \omega_0 L = 104.72 \times 40 \times 10^{-3} = 4.188\ \Omega$$

$$Z_L = \sqrt{5^2 + (4.188)^2} = 6.52\ \Omega$$

$$\theta = \tan^{-1}(\omega_0 L/R) \cong 40^\circ$$

(a) For $0 \leq \alpha \leq \pi$, rms value of output voltage,

$$\begin{aligned} E_o &= E \cdot \left[\frac{1}{\pi} \left(\pi - \alpha_p + \frac{\sin 2\alpha_p}{2} \right) \right]^{1/2} \\ &= 230 \cdot \left[\frac{1}{\pi} \left\{ \left(\pi - \frac{2\pi}{3} \right) + \frac{\sin 240}{2} \right\} \right]^{1/2} \\ &= 101.6\text{ V} \end{aligned}$$

(b) RMS value of load current, $I_o = \frac{E_o}{Z_L}$

$$= \frac{101.6}{4.188} = 24.26\text{ A}$$

The rms current through each converter group is

$$I_p = I_N = \frac{I_o}{\sqrt{2}} = 17.1542 \text{ A.}$$

and the rms current through each thyristor

$$I_{T_{rms}} = \frac{I_p}{\sqrt{2}} = \frac{17.1542}{\sqrt{2}} = 12.13 \text{ A.}$$

(c) rms input current, $I_i = I_o = 24.26 \text{ A.}$

The volt-amp rating = $E \cdot I_i = 230 \times 24.26 = 5580 \text{ VA}$

The output power, $P_o = E_o \cdot I_o \cdot \cos \theta = 101.6 \times 24.26 \times \cos 40^\circ$
 $= 1888.1 \text{ watts.}$

$$\therefore \text{Power factor} = \frac{P_o}{E \cdot I_i} = \frac{1888}{5580}$$

$$= 0.3384 \text{ (lagging)}$$

Now,

$$\text{P.F.} = \frac{m_f}{\sqrt{2}} \cdot \cos \phi$$

$$m_f = \cos (180 - \alpha_p) = \cos 60^\circ = 0.5$$

$$\cos \phi = \cos 40 = 0.766.$$

Hence,

$$P_f = \frac{0.5}{\sqrt{2}} \cdot \cos 40 = 0.27$$

- In a standard A single-phase bridge-type cyclo-converter has input voltage of 230V, 50Hz and load of $R=10\Omega$. Output frequency is one-third of input frequency. For a firing angle delay of 30° , Calculate (i) rms value of output voltage (ii) rms current of each converter (iii) rms current of each thyristor (iv) input power factor.
- A single-phase to single-phase mid-point cyclo-converter is delivering power to a resistive load. The supply transformer has turns ratio of 1: 1: 1. The frequency ratio is $f_o/f_s = 1/5$. The firing angle delay α for all the four SCRs are the same. Sketch the time variations of the following waveforms for $\alpha = 0^\circ$ and $\alpha = 30^\circ$ (a) Supply voltage (b) Output current and (c) Supply current. Indicate the conduction of various thyristors also.