

ELECTRICAL AND ELECTRONICS ENGINEERING
LECTURE NOTES

Course Title : POWER ELECTRONICS

Course Code : 23EE501

Regulation : NR23

UNIT – III
DC – DC converters

3.1 Introduction to Choppers

A chopper uses high speed to connect and disconnect from a source load. A fixed DC voltage is applied intermittently to the source load by continuously triggering the power switch ON/OFF. The period of time for which the power switch stays ON or OFF is referred to as the choppers ON and OFF state times, respectively.

Choppers are mostly applied in electric cars, conversion of wind and solar energy, and DC motor regulators.

Symbol of a Chopper

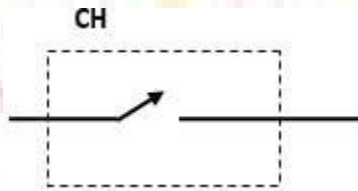

Figure: 3.1 symbol of chopper

3.2 Control strategies of Chopper

In DC-DC converters, the average output voltage is controlled by varying the alpha (α) value. This is achieved by varying the Duty Cycle of the switching pulses. Duty cycle can be varied usually in 2 ways:

1. Time Ratio Control
2. Current Limit Control

In this post we shall look upon both the ways of varying the duty cycle. Duty Cycle is the ratio of „On Time“ to „Time Period of a pulse“.

Time Ratio Control: As the name suggest, here the time ratio (i.e. the duty cycle ratio T_{on}/T) is varied. This

kind of control can be achieved using 2 ways:

- Pulse Width Modulation (PWM) • Frequency Modulation Control (FMC)

Pulse Width Modulation (PWM)

In this technique, the time period is kept constant, but the „On Time“ or the „OFF Time“ is varied. Using this, the duty cycle ratio can be varied. Since the ON time or the „pulse width“ is getting changed in this method, so it is popularly known as Pulse width modulation.

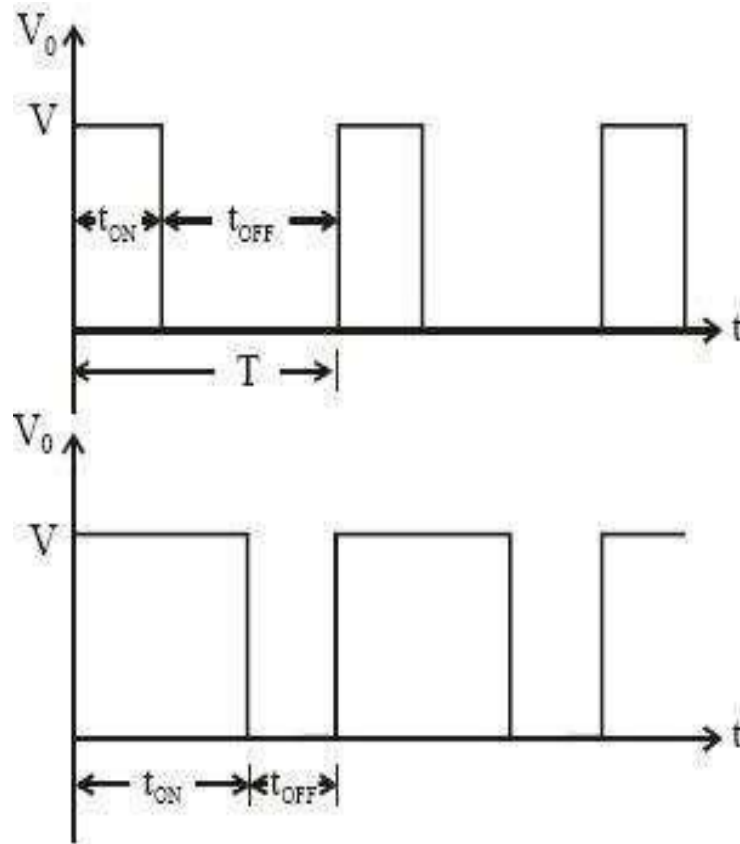

Figure: 3.2 pulse width modulation waveforms

Frequency Modulation Control (FMC)

In this control method, the „Time Period“ is varied while keeping either of „On Time“ or „OFF time“ as constant. In this method, since the time period gets changed, so the frequency also changes accordingly, so this method is known as frequency modulation control.

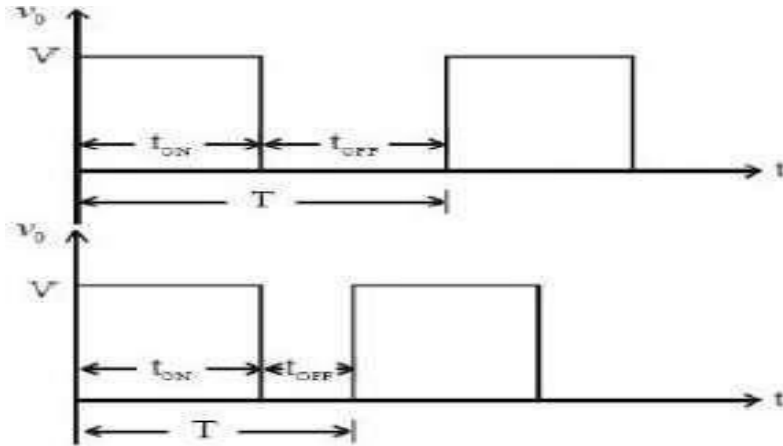

Figure: 3.3 Frequency modulation waveforms

Current Limit Control:

As is obvious from its name, in this control strategy, a specific limit is applied on the current variation.

In this method, current is allowed to fluctuate or change only between 2 values i.e. maximum current (I_{max}) and minimum current (I_{min}). When the current is at minimum value, the chopper is switched ON. After this instance, the current starts increasing, and when it reaches up to maximum value, the chopper is switched off allowing the current to fall back to minimum value. This cycle continues again and again.

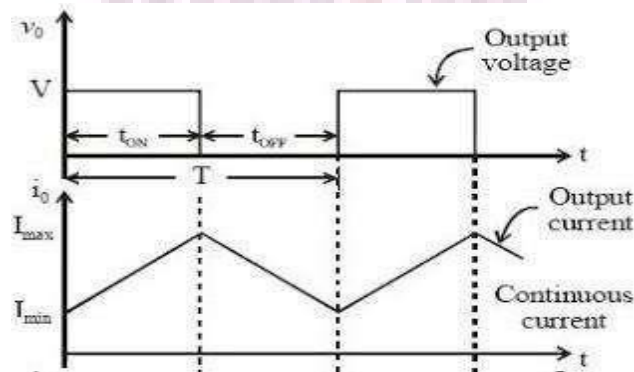

Figure: 3.4 current limit control waveforms

3.3 Classification of Choppers

Depending on the voltage output, choppers are classified as –

1. Step Up chopper (boost converter)
2. Step Down Chopper(Buck converter)

3. Step Up/Down Chopper (Buck-boost converter)

Depending upon the direction of the output current and voltage, the converters can be classified into five classes namely

1. Class A [One-quadrant Operation]
2. Class B [One-quadrant Operation]
3. Class C [Two-quadrant Operation]
4. Class D Chopper [Two-quadrant Operation]
5. Class E Chopper [Four-quadrant Operation]

3.4 Step Down Chopper

This is also known as a buck converter. In this chopper, the average voltage output V_O is less than the input voltage V_S . When the chopper is ON, $V_O = V_S$ and when the chopper is off, $V_O = 0$

When the chopper is ON –

$$V_S = (V_L + V_O), \quad V_L = V_S - V_O,$$

$$L \frac{di}{dt} = V_S - V_O,$$

$$L \Delta i / T_{ON} = V_S - V_O$$

$$V_S = (V_L + V_O),$$

$$V_L = V_S - V_O,$$

$$L \frac{di}{dt} = V_S - V_O,$$

$$L \Delta i / T_{ON} = V_S - V_O$$

Thus, peak-to-peak current load is given by,

$$\Delta i = \frac{V_S - V_O}{L} T_{ON}$$

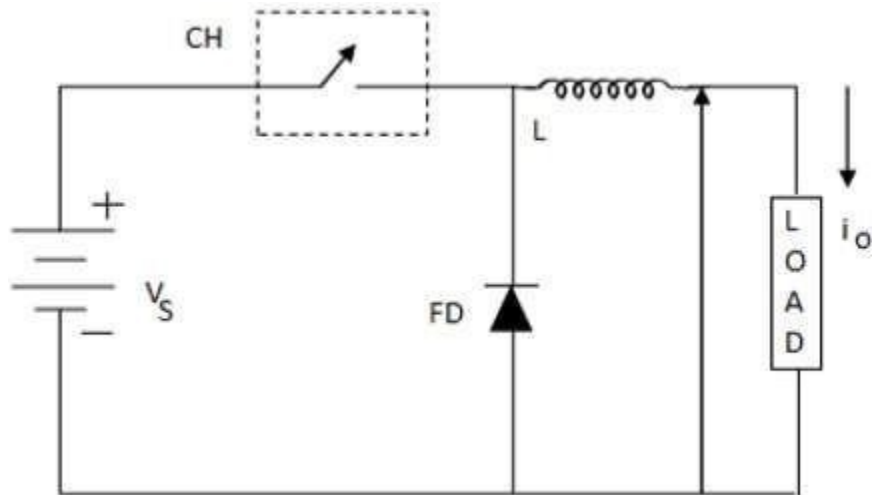
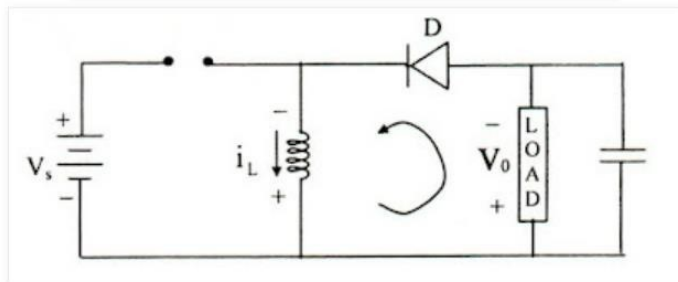
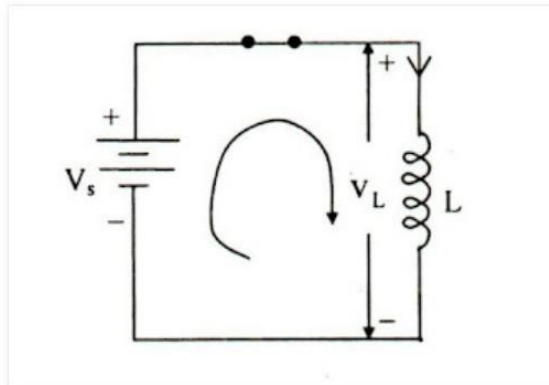
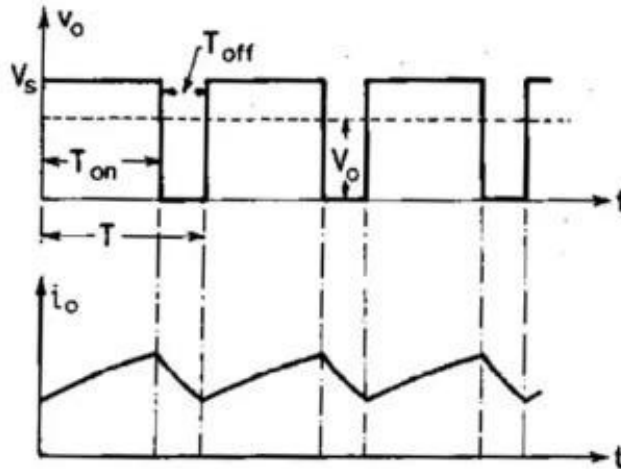

Figure: 3.5 Step down chopper





Where **FD** is free-wheel diode.

When the chopper is OFF, polarity reversal and discharging occurs at the inductor. The current passes through the free-wheel diode and the inductor to the load. This gives,

$$L \frac{di}{dt} = -V_0$$

$$\text{Rewritten as } L \Delta i / T_{OFF} = -V_0$$

$$L \Delta i / T_{OFF} = -V_0$$

$$\Delta i = -V_0 T_{OFF} / L$$

From the above equations

$$\frac{V_s - V_0}{L} T_{ON} = \frac{V_0}{L} T_{OFF}$$

$$\frac{V_s - V_0}{V_0} = \frac{T_{OFF}}{T_{ON}}$$

$$\frac{V_s}{V_0} = \frac{T_{ON} - T_{OFF}}{T_{ON}}$$

$$V_0 = \frac{T_{ON}}{T} V_s = D V_s$$

$$\begin{aligned} \Delta i &= \frac{V_s - D V_s}{L} D T, \text{ from } D = \frac{T_{ON}}{T} \\ &= \frac{V_s (1 - D) D}{L f} \end{aligned}$$

$$f = \frac{1}{T} = \text{chopping frequency}$$

Current and Voltage Waveforms

The current and voltage waveforms are given below –

For a step down chopper the voltage output is always less than the voltage input. This is shown by the waveform below.

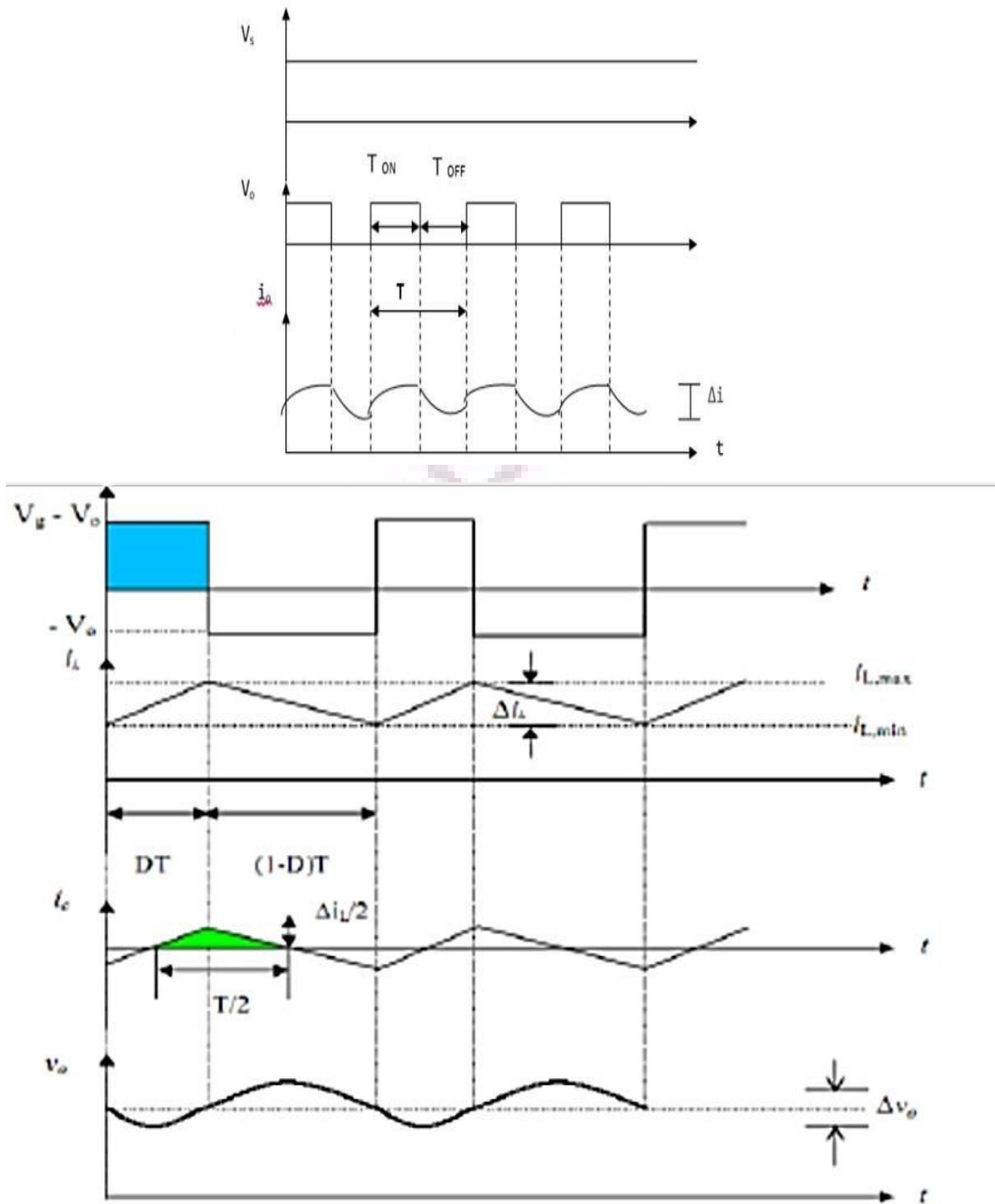

Figure: 3.6 Input and output waveforms

3.5 Step Up Chopper

The average voltage output (V_o) in a step up chopper is greater than the voltage input (V_s). The figure below shows a configuration of a step up chopper.

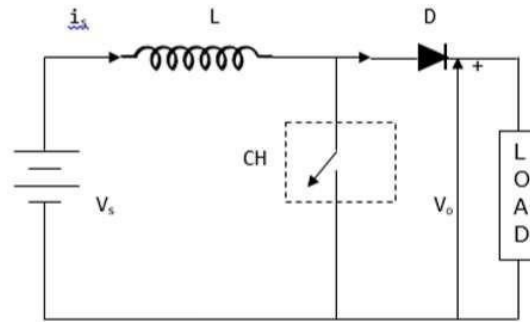
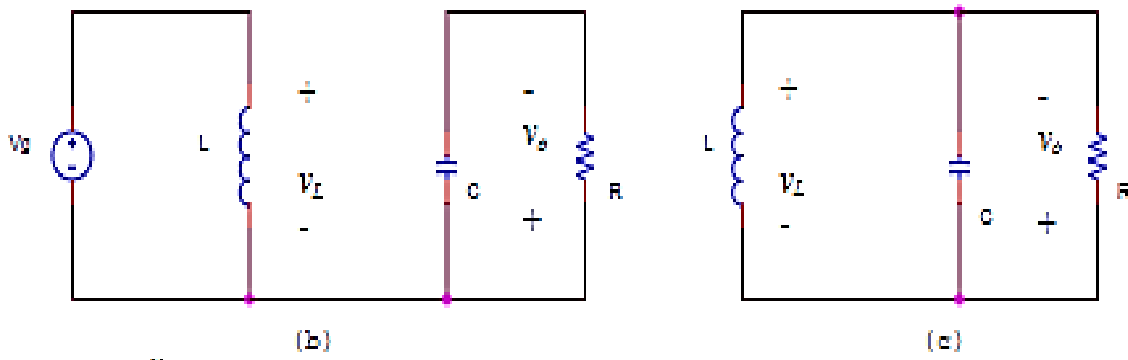
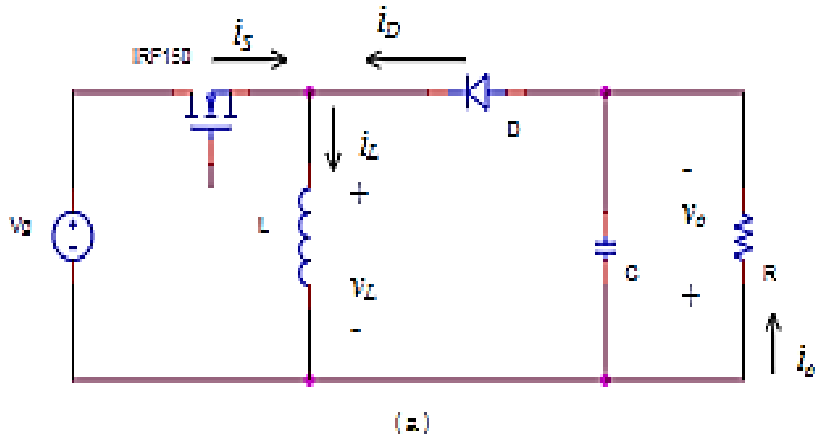

Figure: 3.7 circuit diagram of step up chopper



Current and Voltage Waveforms

V_o (average voltage output) is positive when chopper is switched ON and negative when the chopper is OFF as shown in the waveform below.

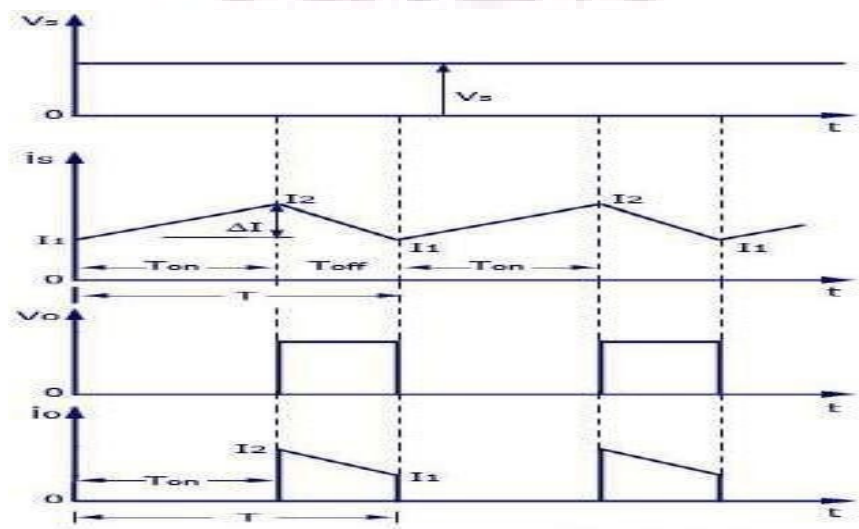
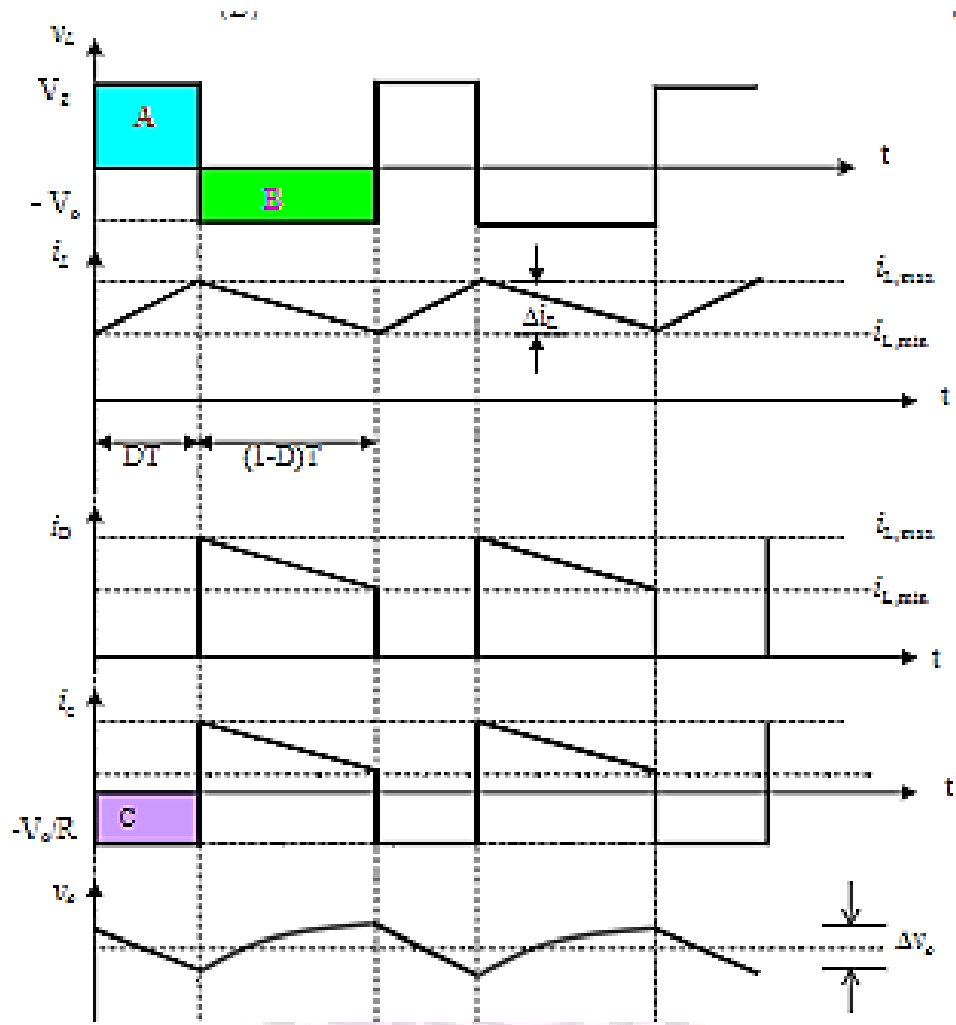

Figure: 3.8 Input and output waveforms of step up chopper

Where

T_{ON} – time interval when chopper is ON

T_{OFF} – time interval when chopper is OFF

V_L – Load voltage

V_s – Source voltage

T – Chopping time period = $T_{ON} + T_{OFF}$

V_o is given by –

$$V_o = \frac{1}{T} \int_0^{T_{on}} V_s dt$$

When the chopper (CH) is switched ON, the load is short circuited and, therefore, the voltage output for the period T_{ON} is zero. In addition, the inductor is charged during this time. This gives $V_s = V_L$

$$V_s = L \frac{di}{dt}, \frac{\Delta i}{T_{on}} = \frac{V_s}{L}$$

$$\Delta i = \frac{V_s}{L} \times T_{on}$$

Δi is the inductor peak to peak current. When the chopper (CH) is OFF, discharge occurs through the inductor L . Therefore, the summation of the V_s and V_L is given as follows –

$$V_o = V_s + V_L, V_L = V_o - V_s$$

$$L \frac{di}{dt} = V_o - V_s$$

$$L \frac{\Delta i}{T_{off}} = V_o - V_s$$

$$\Delta i = \frac{V_o - V_s}{L} T_{off}$$

Equating Δi from on state to off state

$$\frac{TV_s}{T_{off}}$$

$$V_o =$$

$$V_o = \frac{V_s}{1 - D}$$

3.6 StepUp/StepDownChopper

This is also known as a buck-boost converter. It makes it possible to increase or reduce the voltage input level. The diagram below shows a buck-boost chopper

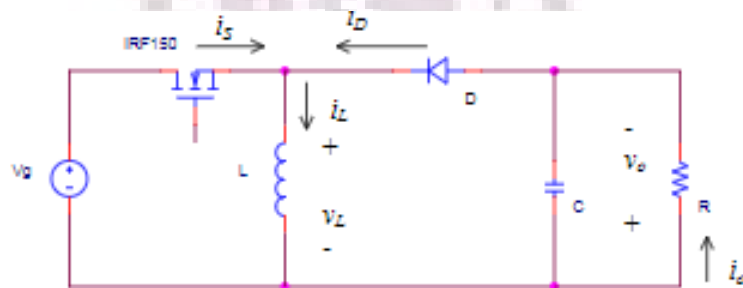
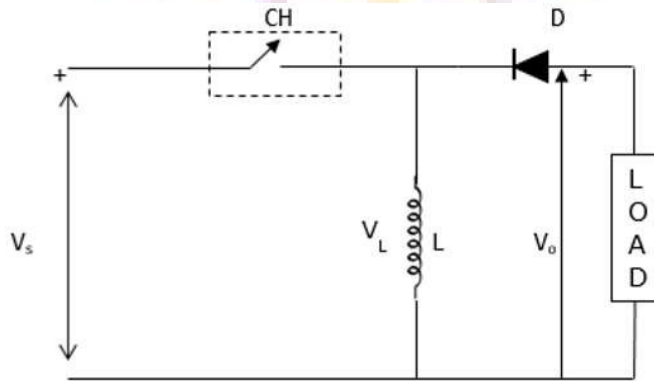

(a)

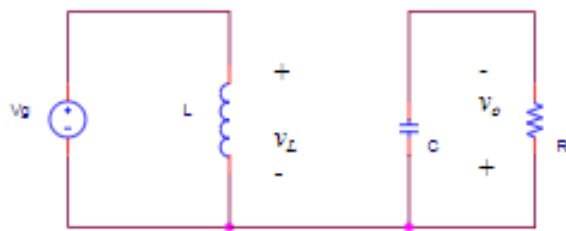

(b)

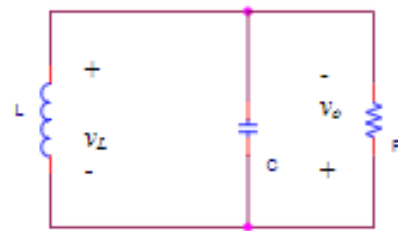

(c)

Figure: 3.9 circuit diagram of step up / Steep down chopper

Power Electronics (EE3202PC)

When the chopper is switched ON, the inductor L becomes charged by the source voltage V_s .

Therefore, $V_s = V_L$.

$$V_s = L \frac{di}{dt}, \frac{\Delta i}{T_{on}} = \frac{V_s}{L}$$

$$\Delta i = \frac{V_s}{L} T_{on} \times \frac{T}{T}$$

$$\Delta i = \frac{DV_s}{Lf}$$

For a buck-boost converter, it is obvious that

$$I_L = I_o + I_s$$

$$\begin{aligned} \Delta i_L &= \frac{1}{L} \int_0^{DT} v_L dt \\ &= \frac{1}{L} [\text{Shaded area under waveform } v_L \text{ (Area A)}] \\ &= \frac{1}{L} V_s \times DT \end{aligned}$$

From Δi_L , we can obtain $i_{L, \min}$ and $i_{L, \max}$

$$i_{L, \min} = I_L - \frac{\Delta i_L}{2}$$

$$i_{L, \max} = I_L + \frac{\Delta i_L}{2}$$

To obtain the average inductor current, we can use this relationship

$$I_o = I_s = (1-D)I_L$$

Therefore

$$I_L = \frac{I_o}{(1-D)} = \frac{V_o}{(1-D)R}$$

$$\begin{aligned} I_L &= \frac{\Delta i_L}{2} \\ \frac{V_o}{R(1-D)} &= \frac{1}{2L} V_s (1-D) T \\ \therefore L_{\min} &= \frac{(1-D)^2 T \times R}{2} \\ &= \frac{(1-D)^2 R}{2f} \end{aligned}$$

If the desired value of the inductor L and the load resistance R are established, the minimum switching frequency required for CCM is

$$f_{\min} = \frac{(1-D)^2 R}{2L}$$

If the desired switching frequency and the value of the inductor L are established, the minimum load resistance required for CCM is

$$R_{\min} = \frac{2fL}{(1-D)^2}$$

When the chopper is switched OFF, the inductor's polarity reverses and this causes it to discharge through the diode and the load.

Hence,

$$V_0 = -V_L$$

$$L \frac{di}{dt} = -V_L$$

$$L \frac{\Delta i}{T_{off}} = -V_L$$

$$\Delta i = -\frac{V_L T_{off}}{L}$$

By comparing the above equations

$$\frac{DV_s}{Lf} = -\frac{V_L T_{off}}{L}$$

$$V_0 = \frac{DV_s}{1-D}$$

3.7 Principle of operation of class A chopper

Class A Chopper is a first quadrant chopper

- When chopper is ON, supply voltage V is connected across the load.
- When chopper is OFF, $v_0 = 0$ and the load current continues to flow in the same direction through the FWD.
- The average values of output voltage and current are always positive. Class A Chopper is a first quadrant chopper
- When chopper is ON, supply voltage V is connected across the load.
- When chopper is OFF, $v_0 = 0$ and the load current continues to flow in the same direction through the FWD.
- The average values of output voltage and current are always positive.
- Class A Chopper is a step-down chopper in which power always flows from source to load.
- It is used to control the speed of dc motor.
- The output current equations obtained in step down chopper with R-L load can be used to study the

performance of Class A Chopper.

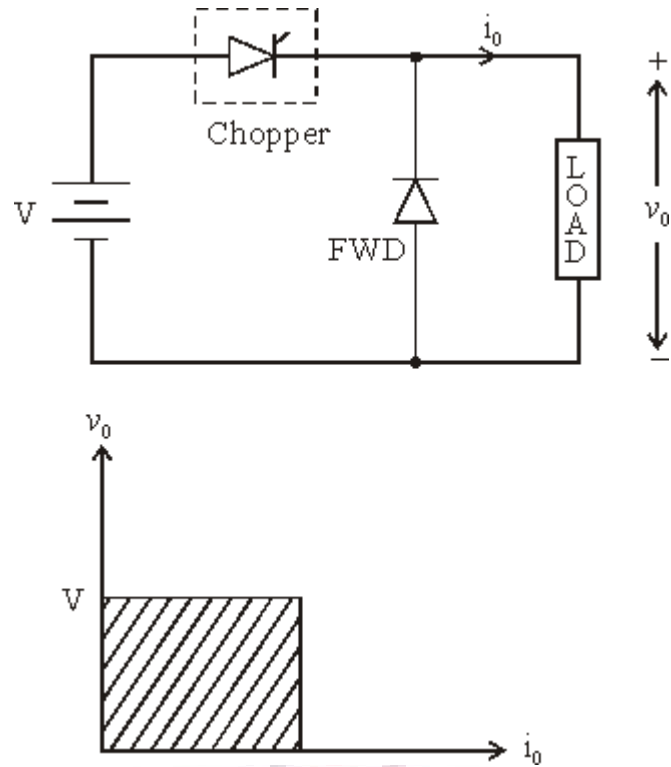

Figure: 3.10 circuit diagram and quadrant operation of Type A chopper

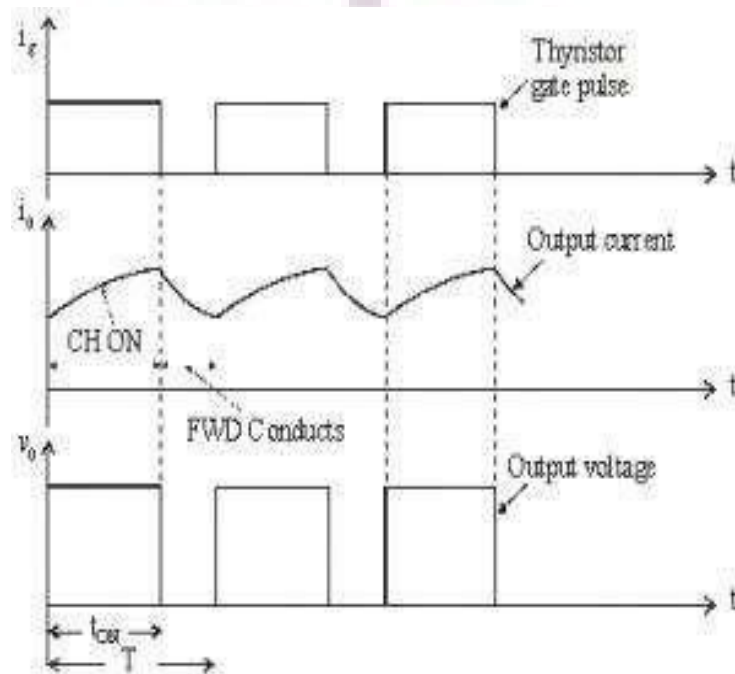

Figure: 3.11 Output voltage and current waveforms of type A chopper

Voltage equation for the circuit shown in figure is

$$V = i_o R + L \frac{di_o}{dt} + E$$

Taking Laplace Transform

$$\frac{V}{S} = RI_o(S) + L[S I_o(S) - i_o(0^-)] + \frac{E}{S}$$

At $t = 0$, initial current $i_o(0^-) = I_{\min}$

$$I_o(S) = \frac{V - E}{LS \left(S + \frac{R}{L} \right)} + \frac{I_{\min}}{S + \frac{R}{L}}$$

Taking Inverse Laplace Transform

$$i_o(t) = \frac{V - E}{R} \left[1 - e^{-\left(\frac{R}{L}\right)t} \right] + I_{\min} e^{-\left(\frac{R}{L}\right)t}$$

This expression is valid for $0 \leq t \leq t_{ON}$. i.e., during the period chopper is ON.

At the instant the chopper is turned off, load current is

$$i_o(t_{ON}) = I_{\max}$$

When Chopper is OFF ($0 \leq t \leq t_{OFF}$)

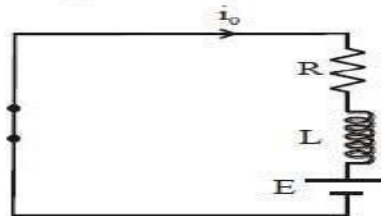

Voltage equation for the circuit shown in figure is

$$0 = Ri_o + L \frac{di_o}{dt} + E$$

Taking Laplace transform

$$0 = RI_o(S) + L[S I_o(S) - i_o(0^-)] + \frac{E}{S}$$

Redefining time origin we have at $t = 0$, initial current $i_o(0^-) = I_{\max}$

Therefore
$$I_o(S) = \frac{I_{\max}}{S + \frac{R}{L}} - \frac{E}{LS \left(S + \frac{R}{L} \right)}$$

Taking Inverse Laplace Transform

$$i_o(t) = I_{\max} e^{-\frac{R}{L}t} - \frac{E}{R} \left[1 - e^{-\frac{R}{L}t} \right]$$

The expression is valid for $0 \leq t \leq t_{OFF}$, i.e., during the period chopper is OFF. At the instant the chopper is turned ON or at the end of the off period, the load current is

$$i_o(t_{OFF}) = I_{\min}$$

TO FIND I_{\max} AND I_{\min}

At $t = t_{ON} = dT$, $i_o(t) = I_{\max}$

3.8 Class B Chopper

Class B Chopper is a step-up chopper

- When chopper is ON, E drives a current through L and R in a direction opposite to that shown in figure.
- During the ON period of the chopper, the inductance L stores energy.
- When Chopper is OFF, diode D conducts, and part of the energy stored in inductor L is returned to the supply.
- Average output voltage is positive. Average output current is negative.
- Therefore Class B Chopper operates in second quadrant.
- In this chopper, power flows from load to source.
- Class B Chopper is used for regenerative braking of dc motor.

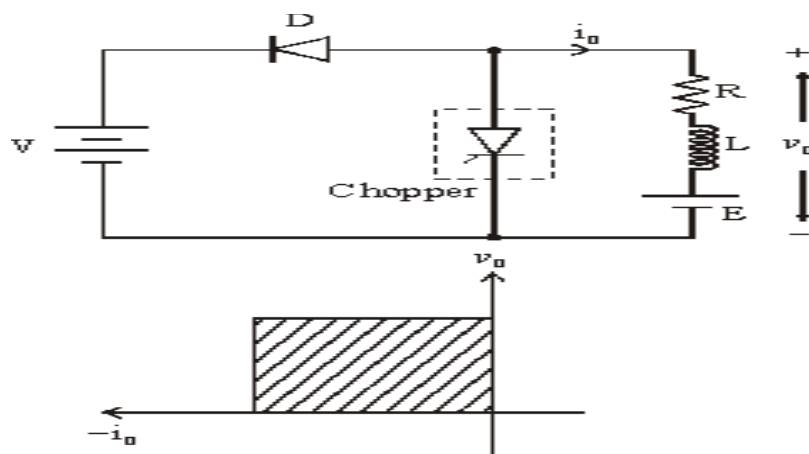

Figure: 3.12 circuit diagram and quadrant operation of Type B chopper

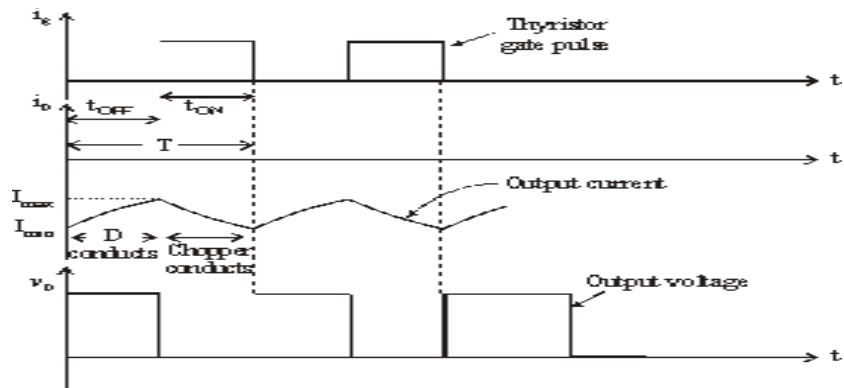

Figure: 3.13 Output voltage and current waveforms of type B chopper

3.9 Class C chopper

Class C Chopper can be used as a step-up or step-down chopper

- Class C Chopper is a combination of Class A and Class B Choppers.
- For first quadrant operation, CH1 is ON or D2 conducts.
- For second quadrant operation, CH2 is ON or D1 conducts.
- When CH1 is ON, the load current is positive.
- The output voltage is equal to „V“ & the load receives power from the source.
- When CH1 is turned OFF, energy stored in inductance L forces current to flow through the diode D2 and the output voltage is zero.
- Current continues to flow in positive direction.
- When CH2 is triggered, the voltage E forces current to flow in opposite direction through L and CH2 .
- The output voltage is zero.
- On turning OFF CH2 , the energy stored in the inductance drives current through diode D1 and the supply
- Output voltage is V, the input current becomes negative and power flows from load to source.
- Average output voltage is positive
- Average output current can take both positive and negative values.
- Choppers CH1 & CH2 should not be turned ON simultaneously as it would result in short circuiting the supply.
- Class C Chopper can be used both for dc motor control and regenerative braking of dc motor.

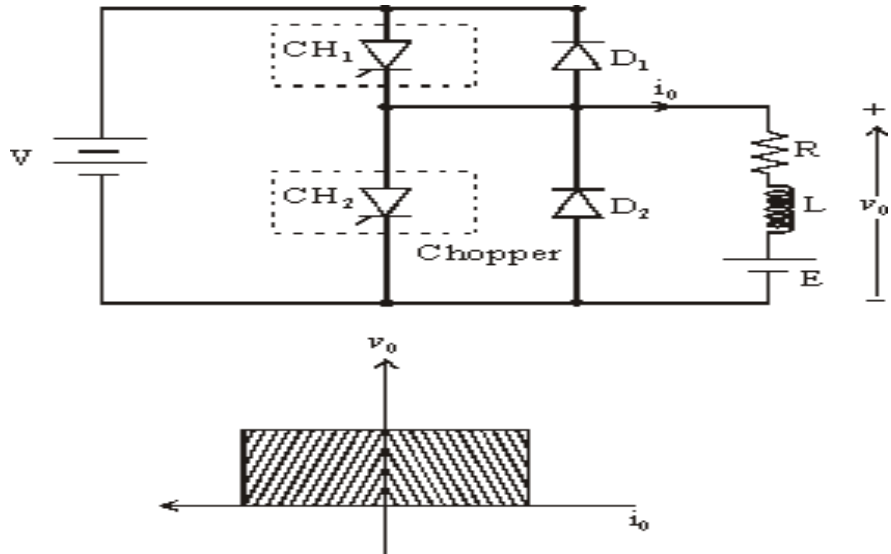

Figure: 3.14 circuit diagram and quadrant operation of Type C chopper

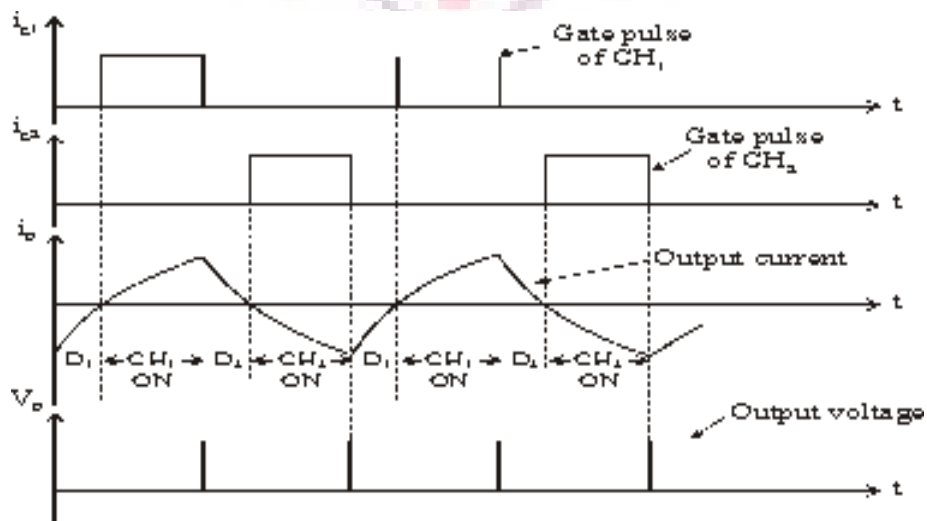

Figure: 3.15 Output voltage and current waveforms of type C chopper

3.10 Class D chopper

- Class D is a two quadrant chopper.
- When both CH1 and CH2 are triggered simultaneously, the output voltage $v_o = V$ and output current flows through the load.
- When CH1 and CH2 are turned OFF, the load current continues to flow in the same direction through load, D1 and D2, due to the energy stored in the inductor L.

- Output voltage $v_o = -V$.
- Average load voltage is positive if chopper ON time is more than the OFF time
- Average output voltage becomes negative if $t_{ON} < t_{OFF}$.
- Hence the direction of load current is always positive but load voltage can be positive or negative.

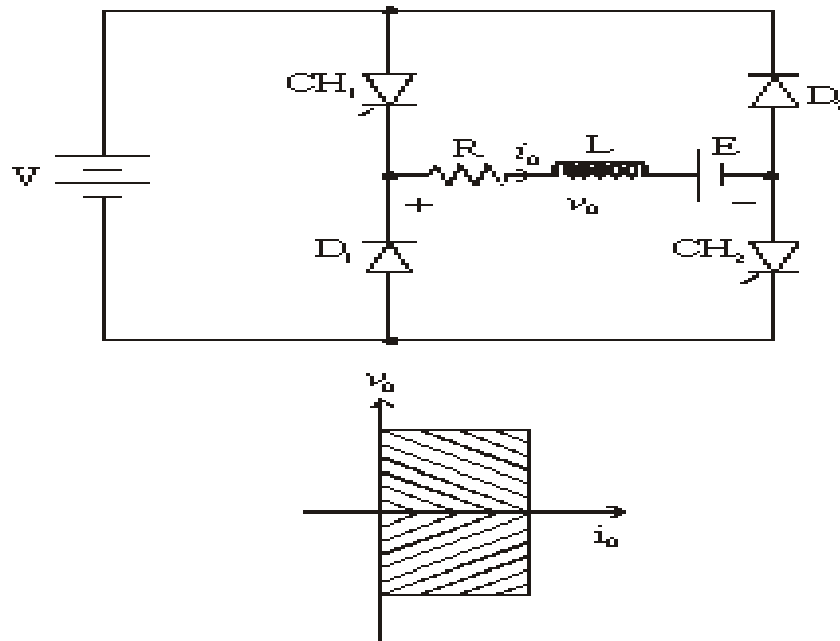

Figure: 3.16 circuit diagram and quadrant operation of Type D chopper

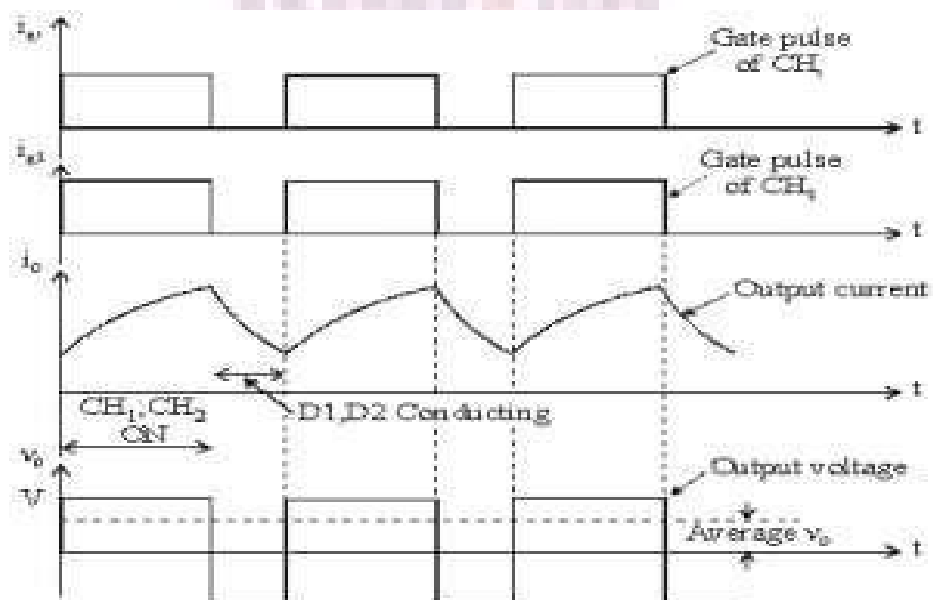

Figure: 3.17 Output voltage and current waveforms of type D chopper

3.11 Class E Chopper

- Class E is a four quadrant chopper
- When CH1 and CH4 are triggered, output current i_O flows in positive direction through CH1 and CH4, and with output voltage $v_O = V$.
- This gives the first quadrant operation.
- When both CH1 and CH4 are OFF, the energy stored in the inductor L drives i_O through D2 and D3 in the same direction, but output voltage $v_O = -V$.
- Therefore the chopper operates in the fourth quadrant.
- When CH2 and CH3 are triggered, the load current i_O flows in opposite direction & output voltage $v_O = -V$.
- Since both i_O and v_O are negative, the chopper operates in third quadrant.
- When both CH2 and CH3 are OFF, the load current i_O continues to flow in the same direction D1 and D4 and the output voltage $v_O = V$.
- Therefore the chopper operates in second quadrant as v_O is positive but i_O is negative.

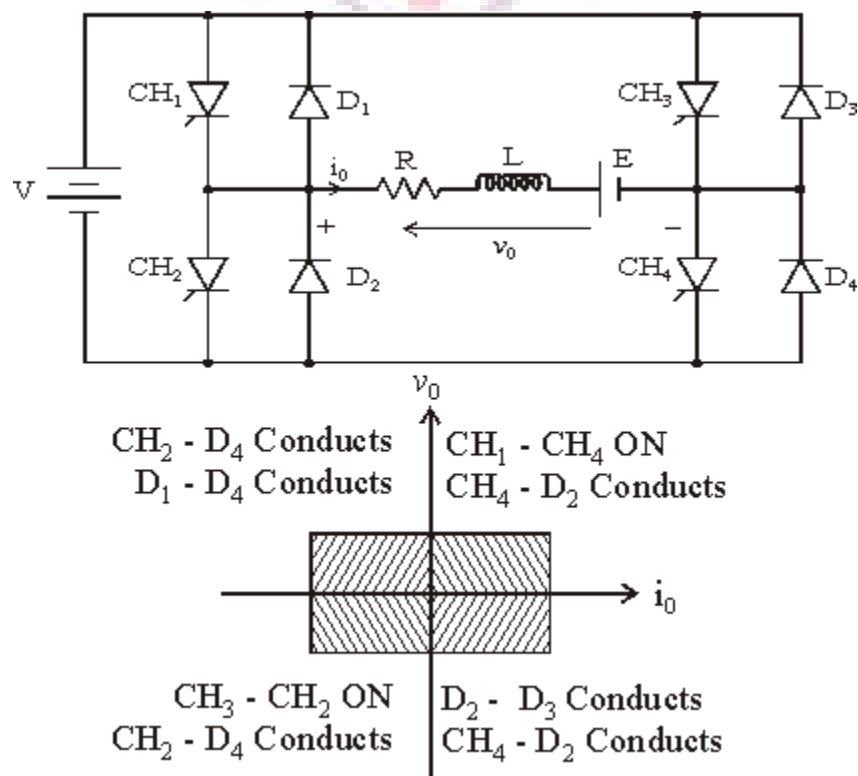

Figure: 3.18 circuit diagram and quadrant operation of Type E chopper

Numerical problems

1. A step up chopper has an input voltage of 150V. The voltage output needed is 450V. Given, that the thyristor has a conducting time of 150μseconds. Calculate the chopping frequency.

Solution –

The chopping frequency (f)

$$f = \frac{1}{T}$$

Where T - Chopping time period = $T_{ON} + T_{OFF}$

Given – $V_S = 150V$ $V_0 = 450V$ $T_{ON} = 150\mu sec$

$$V_0 = V_S \left(\frac{T}{T - T_{ON}} \right)$$

$$450 = 150 \frac{T}{T - 150 \times 10^{-6}} \quad T = 225\mu sec$$

Therefore, $f = \frac{1}{225 \times 10^{-6}} = 4.44KHz$

The new voltage output, on condition that the operation is at constant frequency after the halving the pulse width.

Halving the pulse width gives –

$$T_{ON} = \frac{150 \times 10^{-6}}{2} = 75\mu sec$$

The frequency is constant thus,

$$f = 4.44KHz$$

$$T = \frac{1}{f} = 150\mu sec$$

The voltage output is given by –

$$V_0 = V_S \left(\frac{T}{T - T_{ON}} \right) = 150 \times \left(\frac{150 \times 10^{-6}}{(150 - 75) \times 10^{-6}} \right) = 300V$$

2. In a type A chopper, the input supply voltage is 230 V the load resistance is 10Ω and there is a voltage drop of 2 V across the chopper thyristor when it is on. For a duty ratio of 0.4, calculate the average and rms values of the output voltage. Also find the chopper efficiency
3. A step-up chopper supplies a load of 480 V from 230 V dc supply. Assuming the non conduction period of the thyristor to be 50 microsecond, find the on time of the thyristor

Buck regulator

With power being a key parameter in many designs, step down or "buck" regulators are widely used.

Although a resistor would enable voltage to be dropped, power is lost, and in applications such as the many battery powered items used today, power consumption is a crucial element.

As a result step down switch mode converters or as they are more commonly termed, buck regulators are widely used.

Linear step down

The most basic form of step down transition is to use a resistor as a potential divider or voltage dropper. In some cases a zener diode may also be used to stabilize the voltage.

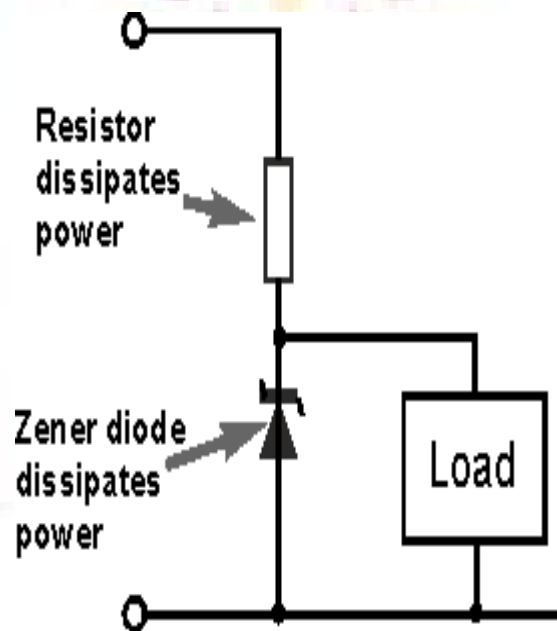

Figure: 3.19 Potential divider circuits

The issue with this form of voltage dropper or step down converter is that it is very wasteful in terms of power. Any voltage dropped across the resistor will be dissipated as heat, and any current flowing through the zener diode will also dissipate heat. Both of these elements result on the loss of valuable energy.

Basic buck converter or regulator

The fundamental circuit for a step down converter or buck converter consists of an inductor, diode, capacitor, switch and error amplifier with switch control circuitry.

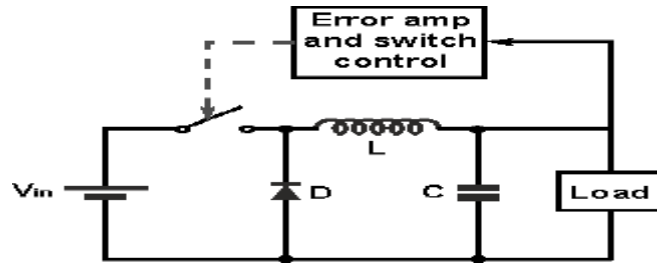

Figure: 3.20 circuit diagram of Buck regulator

The circuit for the buck regulator operates by varying the amount of time in which inductor receives energy from the source.

In the basic block diagram the operation of the buck converter or buck regulator can be seen that the output voltage appearing across the load is sensed by the sense / error amplifier and an error voltage is generated that controls the switch.

Typically the switch is controlled by a pulse width modulator, the switch remaining on of longer as more current is drawn by the load and the voltage tends to drop and often there is a fixed frequency oscillator to drive the switching.

Buck converter operation

When the switch in the buck regulator is on, the voltage that appears across the inductor is $V_{in} - V_{out}$. Using the inductor equations, the current in the inductor will rise at a rate of $(V_{in} - V_{out})/L$. At this time the diode D is reverse biased and does not conduct.

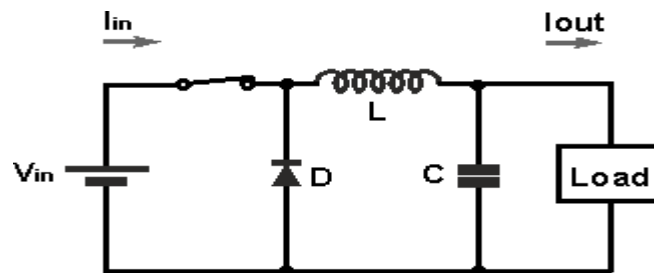

Figure: 3.21 circuit diagram of Buck regulator during switch on condition

When the switch opens, current must still flow as the inductor works to keep the same current flowing. As a result current still flows through the inductor and into the load. The diode, D then forms the return path with a current I_{diode} equal to I_{out} flowing through it.

With the switch open, the polarity of the voltage across the inductor has reversed and therefore the current through the inductor decreases with a slope equal to $-V_{out}/L$.

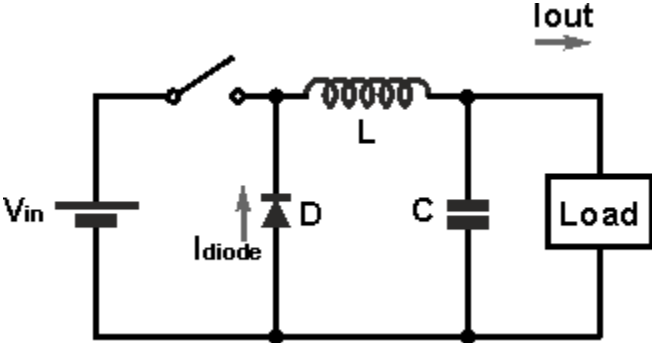

Figure: 3.22 circuit diagram of Buck regulator during switch off condition

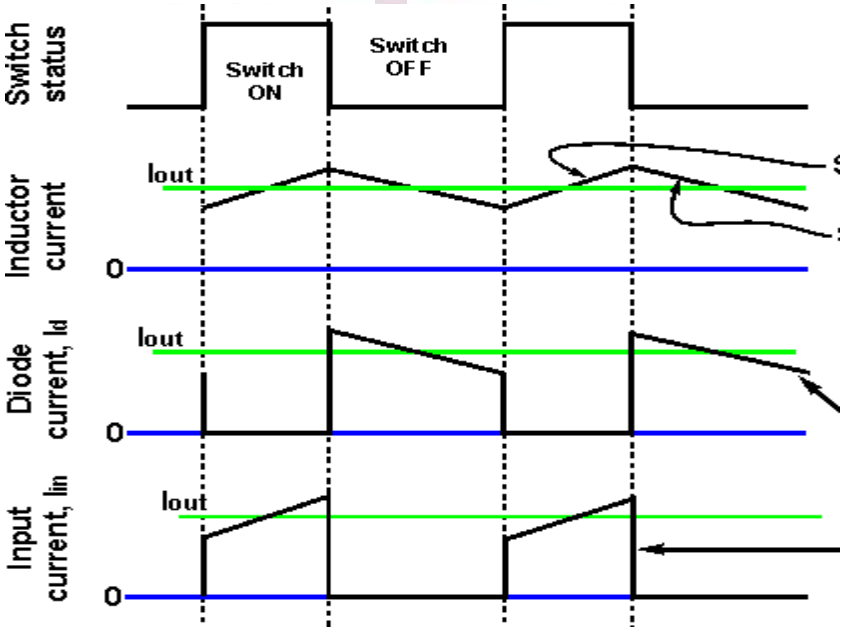

Figure: 3.23 Input and output waveforms of Buck regulator

In the diagram of the current waveforms for the buck converter / switching regulator, it can be seen that the inductor current is the sum of the diode and input / switch current. Current either flows through the switch or the diode.

It is also worth noting that the average input current is less than the average output current. This is to be expected because the buck converter circuit is very efficient and the input voltage is greater than the output voltage. Assuming a perfect circuit, then power in would equal power out, i.e. $V_{in} \cdot I_n = V_{out} \cdot I_{out}$. While in a real circuit there will be some losses, efficiency levels greater than 85% are to be expected for a well-designed circuit.

It will also be seen that there is a smoothing capacitor placed on the output. This serves to ensure that the voltage does not vary appreciably, especially during and switch transition times. It will also be required to smooth any switching spikes that occur.

Boost regulator

One of the advantages of switch mode power supply technology is that it can be used to create a step up or boost converter / regulator.

Boost converters or regulators are used in many instances from providing small supplies where higher voltages may be needed to much higher power requirements.

Often there are requirements for voltages higher than those provided by the available power supply - voltages for RF power amplifiers within mobile phones is just one example.

Step-up boost converter basics

The boost converter circuit has many similarities to the buck converter. However the circuit topology for the boost converter is slightly different. The fundamental circuit for a boost converter or step up converter consists of an inductor, diode, capacitor, switch and error amplifier with switch control circuitry.

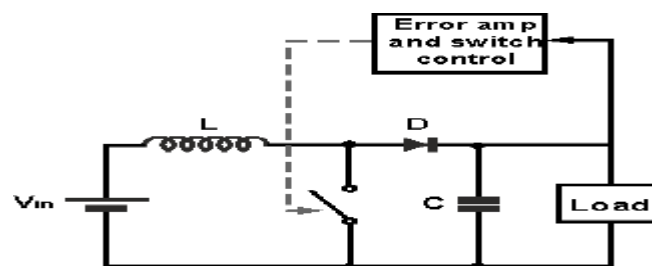

Figure: 3.24 circuit diagram of Boost regulator

The circuit for the step-up boost converter operates by varying the amount of time in which inductor receives energy from the source.

In the basic block diagram the operation of the boost converter can be seen that the output voltage appearing across the load is sensed by the sense / error amplifier and an error voltage is generated that controls the switch.

Typically the boost converter switch is controlled by a pulse width modulator, the switch remaining on for longer as more current is drawn by the load and the voltage tends to drop and often there is a fixed frequency oscillator to drive the switching.

Boost converter operation

The operation of the boost converter is relatively straightforward.

When the switch is in the ON position, the inductor output is connected to ground and the voltage V_{in} is placed across it. The inductor current increases at a rate equal to V_{in}/L .

When the switch is placed in the OFF position, the voltage across the inductor changes and is equal to $V_{out}-V_{in}$. Current that was flowing in the inductor decays at a rate equal to $(V_{out}-V_{in})/L$.

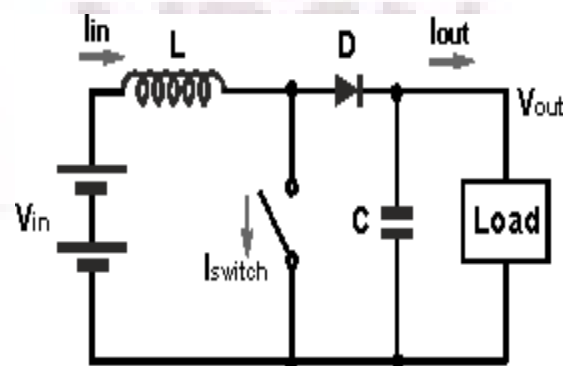

Figure: 3.25 circuit diagram of Boost regulator during switch off condition

Referring to the boost converter circuit diagram, the current waveforms for the different areas of the circuit can be seen as below.

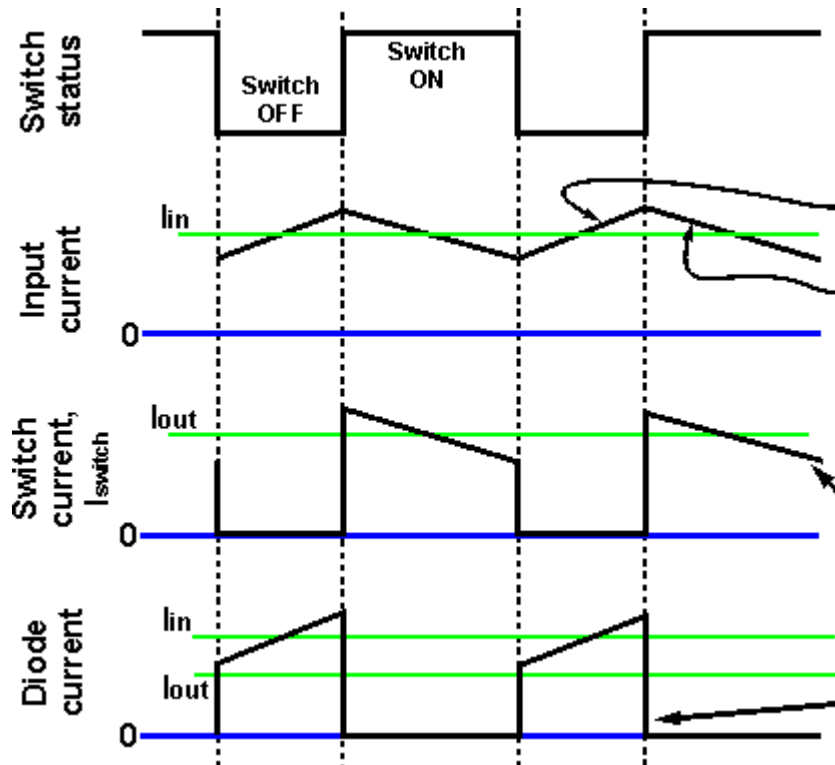

Figure: 3.26 Input and output waveforms of Boost regulator

It can be seen from the waveform diagrams that the input current to the boost converter is higher than the output current. Assuming a perfectly efficient, i.e. lossless, boost converter, the power out must equal the power in, i.e. $V_{in} \cdot I_{in} = V_{out} \cdot I_{out}$. From this it can be seen if the output voltage is higher than the input voltage, then the input current must be higher than the output current.

In reality no boost converter will be lossless, but efficiency levels of around 85% and more are achievable in most supplies.

Buck boost regulator

A simple buck converter can only produce voltages lower than the input voltage, and a boost converter, only voltages higher than the input. To provide voltages over the complete range a circuit known as a buck-boost converter is required.

There are many applications where voltages higher and lower than the input are required. In these situations a buck-boost converter is required.

Buck-Boost Converter basics

The buck-boost DC-DC converter offers a greater level of capability than the buck converter or boost converter individually, it as expected it extra components may be required to provide the level of functionality needed.

There are several formats that can be used for buck-boost converters:

- **+ V_{in} , - V_{out} :** This configuration of a buck-boost converter circuit uses the same number of components as the simple buck or boost converters. However this buck-boost regulator or DC-DC converter produces a negative output for a positive input. While this may be required or can be accommodated for a limited number of applications, it is not normally the most convenient format.

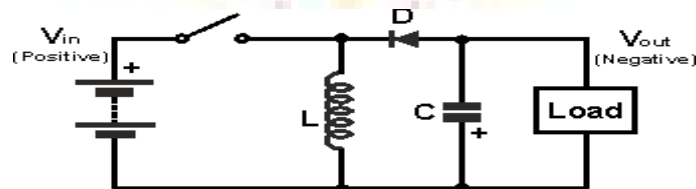

Figure: 3.27 circuit diagram of buck boost regulator

- When the switch is closed, current builds up through the inductor. When the switch is opened the inductor supplies current through the diode to the load.

Obviously the polarities (including the diode) within the buck-boost converter can be reversed to provide a positive output voltage from a negative input voltage.

- **+ V_{in} , + V_{out} :** The second buck-boost converter circuit allows both input and output to be the same polarity. However to achieve this, more components are required. The circuit for this buck boost converter is shown below.

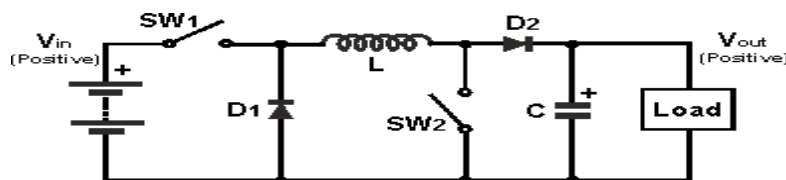

Figure: 3.28 circuit diagram of buck boost regulator with two switches

In this circuit, both switches act together, i.e. both are closed or open. When the switches are open, the inductor current builds. At a suitable point, the switches are opened. The inductor then supplies current to the load through a path incorporating both diodes, D1 and D2.

Numerical problems

1. In a dc chopper, the average load current is 30 Amps, chopping frequency is 250 Hz. Supply voltage is 110 volts. Calculate the ON and OFF periods of the chopper if the load resistance is 2 ohms.

Solution:

$$I_{dc} = 30 \text{ Amps, } f = 250 \text{ Hz, } V = 110 \text{ V, } R = 2\Omega$$

$$\text{Chopping period, } T = \frac{1}{f} = \frac{1}{250} = 4 \times 10^{-3} = 4 \text{ msec}$$

$$I_{dc} = \frac{V_{dc}}{R} \text{ and } V_{dc} = dV$$

$$\text{Therefore } I_{dc} = \frac{dV}{R}$$

$$d = \frac{I_{dc}R}{V} = \frac{30 \times 2}{110} = 0.545$$

$$\text{Chopper ON period, } t_{ON} = dT = 0.545 \times 4 \times 10^{-3} = 2.18 \text{ msec}$$

$$\text{Chopper OFF period, } t_{OFF} = T - t_{ON}$$

$$t_{OFF} = 4 \times 10^{-3} - 2.18 \times 10^{-3}$$

$$t_{OFF} = 1.82 \times 10^{-3} = 1.82 \text{ msec}$$

2. A step up chopper has input voltage of 220 V and output voltage of 660 V. If the non-conducting time of thyristor chopper is 100 micro sec compute the pulse width of output voltage. In case the pulse width is halved for constant frequency operation, find the new output voltage
3. A chopper operating from 220V dc supply with for a duty cycle of 0.5 and chopping frequency of 1KHz drives an R L load with $R = 1\Omega$, $L=1\text{mH}$ and $E = 105\text{V}$. Find whether the current is continuous and also find the values of I_{\max} and I_{\min} .