

UNIT-5

Optical Fiber Transmission Media

Fiber-optic communication is a method of transmitting information from one place to another by sending pulses of light through an optical fiber. The light forms an electromagnetic carrier wave that is modulated to carry information. Fiber is preferred over electrical cabling when high bandwidth, long distance, or immunity to electromagnetic interference are required. This type of communication can transmit voice, video, and telemetry through local area networks, computer networks, or across long distances.

Optical fiber is used by many telecommunications companies to transmit telephone signals, Internet communication, and cable television signals. Researchers at Bell Labs have reached internet speeds of over 100 peta bit ×kilometer per second using fiber-optic communication. The process of communicating using fiber-optics involves the following basic steps:

1. Creating the optical signal involving the use of a transmitter, usually from an electrical signal
2. Relaying the signal along the fiber, ensuring that the signal does not become too distorted or weak
3. Receiving the optical signal
4. Converting it into an electrical signal

Historical Development

First developed in the 1970s, fiber-optics have revolutionized the telecommunications industry and have played a major role in the advent of the Information Age. Because of its advantages over electrical transmission, optical fibers have largely replaced copper wire communications in core networks in the developed world.

In 1880 Alexander Graham Bell and his assistant Charles Sumner Tainter created a very early precursor to fiber-optic communications, the Photophone, at Bell's newly established Volta Laboratory in Washington, D.C. Bell considered it his most important invention. The device allowed for the transmission of sound on a beam of light. On June 3, 1880, Bell conducted the world's first wireless telephone transmission between two buildings, some 213 meters apart. Due to its use of an atmospheric transmission medium, the Photophone would not prove practical until advances in laser and optical fiber technologies permitted the secure transport of light. The Photophone's first

practical use came in military communication systems many decades later.

In 1954 Harold Hopkins and Narinder Singh Kapany showed that rolled fiber glass allowed light to be transmitted. Initially it was considered that the light can traverse in only straight medium. Jun-ichi Nishizawa, a Japanese scientist at Tohoku University, proposed the use of optical fibers for communications in 1963. Nishizawa invented the PIN diode and the static induction transistor, both of which contributed to the development of optical fiber communications.

In 1966 Charles K. Kao and George Hockham at STC Laboratories (STL) showed that the losses of 1,000 dB/km in existing glass (compared to 5–10 dB/km in coaxial cable) were due to contaminants which could potentially be removed.

Optical fiber was successfully developed in 1970 by Corning Glass Works, with attenuation low enough for communication purposes (about 20 dB/km) and at the same time GaAs semiconductor lasers were developed that were compact and therefore suitable for transmitting light through fiber optic cables for long distances. In 1973, Optelecom, Inc., co-founded by the inventor of the laser, Gordon Gould, received a contract from APA for the first optical communication systems. Developed for Army Missile Command in Huntsville, Alabama, it was a laser on the ground and a spout of optical fiber played out by missile to transmit a modulated signal over five kilometers.

After a period of research starting from 1975, the first commercial fiber-optic communications system was developed which operated at a wavelength around 0.8 μm and used GaAs semiconductor lasers. This first-generation system operated at a bit rate of 45 Mbit/s with repeater spacing of up to 10 km. Soon on 22 April 1977, General Telephone and Electronics sent the first live telephone traffic through fiber optics at a 6 Mbit/s throughput in Long Beach, California.

In October 1973, Corning Glass signed a development contract with CSELT and Pirelli aimed to test fiber optics in an urban environment: in September 1977, the second cable in this test series, named COS-2, was experimentally deployed in two lines (9 km) in Turin, for the first time in a big city, at a speed of 140 Mbit/s.

The second generation of fiber-optic communication was developed for commercial use in the early 1980s, operated at 1.3 μm and used InGaAsP semiconductor lasers. These early systems were initially limited by multi mode fiber dispersion, and in 1981 the single-mode fiber was revealed to greatly improve system performance, however practical connectors capable of working with single mode fiber proved difficult to develop. Canadian service provider SaskTel had completed construction of what was then the world's longest commercial fiber optic network, which covered 3,268 km (2,031 mi) and linked 52 communities. By 1987, these systems were operating at bit rates of up to 1.7 Gb/s with repeater spacing up to 50 km (31 mi). The first transatlantic telephone cable to use optical

fiber was TAT-8, based on Desurvire optimised laser amplification technology. It went into operation in 1988.

Third-generation fiber-optic systems operated at 1.55 μm and had losses of about 0.2 dB/km. This development was spurred by the discovery of Indium gallium arsenide and the development of the Indium Gallium Arsenide photodiode by Pearsall. Engineers overcame earlier difficulties with pulse-spreading at that wavelength using conventional InGaAsP semiconductor lasers. Scientists overcame this difficulty by using dispersion-shifted fibers designed to have minimal dispersion at 1.55 μm or by limiting the laser spectrum to a single longitudinal mode. These developments eventually allowed third-generation systems to operate commercially at 2.5 Gbit/s with repeater spacing in excess of 100 km (62 mi).

The fourth generation of fiber-optic communication systems used optical amplification to reduce the need for repeaters and wavelength-division multiplexing to increase data capacity. These two improvements caused a revolution that resulted in the doubling of system capacity every six months starting in 1992 until a bit rate of 10 Tb/s was reached by 2001. In 2006 a bit-rate of 14 Tbit/s was reached over a single 160 km (99 mi) line using optical amplifiers.

The focus of development for the fifth generation of fiber-optic communications is on extending the wavelength range over which a WDM system can operate. The conventional wavelength window, known as the C band, covers the wavelength range 1.53–1.57 μm , and dry fiber has a low-loss window promising an extension of that range to 1.30–1.65 μm . Other developments include the concept of "optical solutions", pulses that preserve their shape by counteracting the effects of dispersion with the nonlinear effects of the fiber by using pulses of a specific shape.

In the late 1990s through 2000, industry promoters, and research companies such as KMI, and RHK predicted massive increases in demand for communications bandwidth due to increased use of the Internet, and commercialization of various bandwidth-intensive consumer services, such as video on demand. Internet protocol data traffic was increasing exponentially, at a faster rate than integrated circuit complexity had increased under Moore's Law. From the bust of the dot-com bubble through 2006, however, the main trend in the industry has been consolidation of firms and off shoring of manufacturing to reduce costs.

Advantages of Fiber Optic Transmission

Optical fibers have largely replaced copper wire communications in core networks in the developed world, because of its advantages over electrical transmission. Here are the main advantages of fiber optic transmission.

Extremely High Bandwidth: No other cable-based data transmission medium offers the

bandwidth that fiber does. The volume of data that fiber optic cables transmit per unit time is far greater than copper cables.

Longer Distance: in fiber optic transmission, optical cables are capable of providing low power loss, which enables signals can be transmitted to a longer distance than copper cables.

Resistance to Electromagnetic Interference: in practical cable deployment, it's inevitable to meet environments like power substations, heating, ventilating and other industrial sources of interference. However, fiber has a very low rate of bit error (10⁻¹³), as a result of fiber being so resistant to electromagnetic interference. Fiber optic transmission is virtually noise free.

Low Security Risk: the growth of the fiber optic communication market is mainly driven by increasing awareness about data security concerns and use of the alternative raw material. Data or signals are transmitted via light in fiber optic transmission. Therefore there is no way to detect the data being transmitted by "listening in" to the electromagnetic energy "leaking" through the cable, which ensures the absolute security of information.

Small Size: fiber optic cable has a very small diameter. For instance, the cable diameter of a single OM3 multimode fiber is about 2mm, which is smaller than that of coaxial copper cable. Small size saves mere space in fiber optic transmission.

Light Weight: fiber optic cables are made of glass or plastic, and they are thinner than copper cables. These make them lighter and easy to install.

Easy to Accommodate Increasing Bandwidth: with the use of fiber optic cable, new equipment can be added to existing cable infrastructure. Because optical cable can provide vastly expanded capacity over the originally laid cable and WDM (wavelength division multiplexing) technology, including CWDM and DWDM, enables fiber cables the ability to accommodate more bandwidth.

Disadvantages of Fiber Optic Transmission

Though fiber optic transmission brings lots of convenience, its disadvantages also cannot be ignored.

Fragility: usually optical fiber cables are made of glass, which lends to they are more fragile than electrical wires. In addition, glass can be affected by various chemicals including hydrogen gas (a problem in underwater cables), making them need more cares when deployed underground.

Difficult to Install: it's not easy to splice fiber optic cable. And if you bend them too much, they will break. And fiber cable is highly susceptible to becoming cut or damaged during installation or construction activities. All these make it difficult to install.

Attenuation & Dispersion: as transmission distance getting longer, light will be attenuated and dispersed, which requires extra optical components like EDFA to be added.

Cost is Higher Than Copper Cable: despite the fact that fiber optic installation costs are dropping by as much as 60% a year, installing fiber optic cabling is still relatively higher than copper cables. Because copper cable installation does not need extra care like fiber cables. However, optical fiber is still moving into the local loop, and through technologies such as FTTx (fiber to the home, premises, etc.) and PONs (passive optical networks), enabling subscriber and end user broadband access.

Special Equipment Is Often Required: to ensure the quality of fiber optic transmission, some special equipment is needed. For example, equipment such as OTDR (optical time-domain reflectometry) is required and expensive, specialized optical test equipment such as optical probes and power meter are needed at most fiber endpoints to properly provide testing of optical fiber.

Applications of Optical Fiber Communications

Fiber optic cables find many uses in a wide variety of industries and applications. Some uses of fiber optic cables include:

Medical -Used as light guides, imaging tools and also as lasers for surgeries

Defense/Government-Used as hydrophones for seismic waves and SONAR , as wiring in aircraft, submarines and other vehicles and also for field networking

Data Storage- Used for data transmission

Telecommunications- Fiber is laid and used for transmitting and receiving purposes

Networking- Used to connect users and servers in a variety of network settings and help increase the speed and accuracy of data transmission

Industrial/Commercial- Used for imaging in hard to reach areas, as wiring where EMI is an issue, as sensory devices to make temperature, pressure and other measurements, and as wiring in automobiles and in industrial settings.

Broadcast/CATV-Broadcast/cable companies are using fiber optic cables for wiring CATV, HDTV, internet, video on- demand and other applications. Fiber optic cables are used for lighting and imaging and as sensors to measure and monitor a vast array of variables. Fiber optic cables are also used in research and development and testing across all the above mentioned industries

The optical fibers have many applications. Some of them are as follows

- ❖ Used in telephone systems
- ❖ Used in sub-marine cable networks
- ❖ Used in data link for computer networks, CATV Systems
- ❖ Used in CCTV surveillance cameras
- ❖ Used for connecting fire, police, and other emergency services.
- ❖ Used in hospitals, schools, and traffic management systems.
- ❖ They have many industrial uses and also used for in heavy duty constructions.

Block Diagram of Optical Fiber Communication System

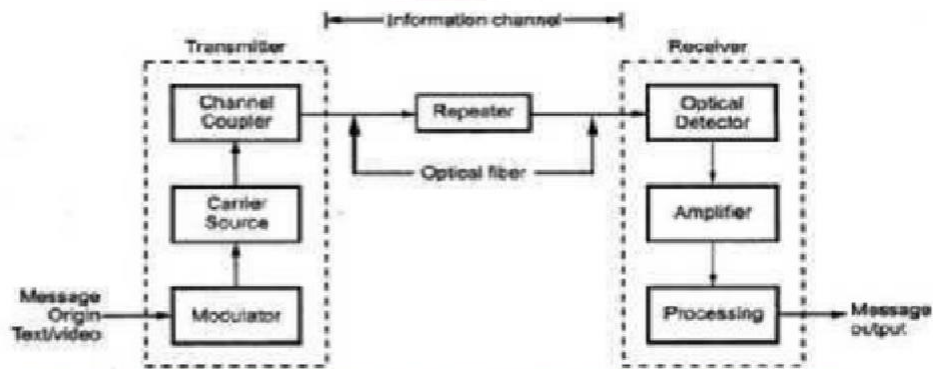

Block Diagram of Optical Fiber Communication System

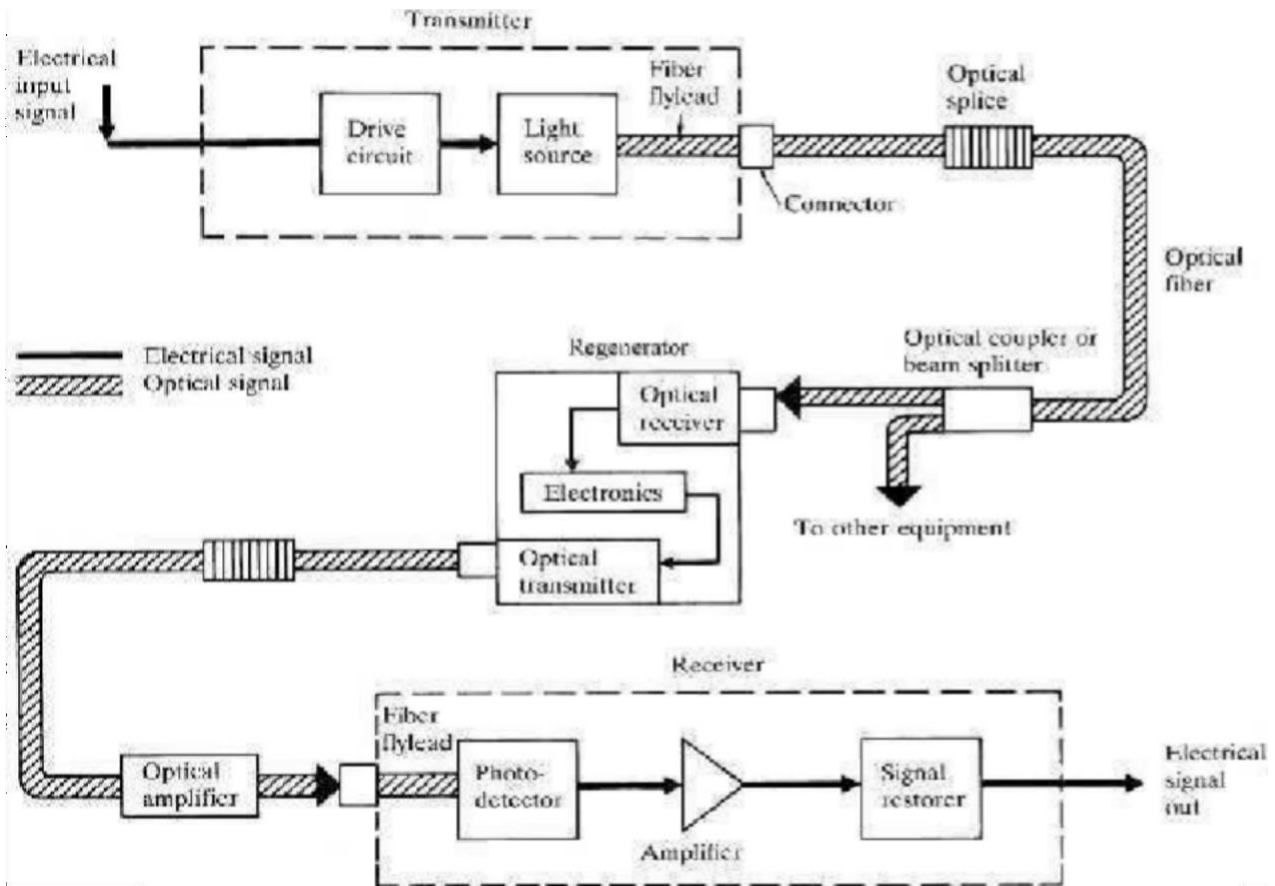

Message origin:

Generally message origin is from a transducer that converts a non-electrical message into an electrical signal. Common examples include microphones for converting sound waves into currents and video (TV) cameras for converting images into current. For data transfer between computers, the message is already in electrical form.

Modulator:

The modulator has two main functions.

- 1) It converts the electrical message into proper format.
- 2) It impresses this signal onto the wave generated by the carrier source.

Two distinct categories of modulation are used i.e. analog modulation and digital modulation.

Carrier source:

Carrier source generates the wave on which the information is transmitted. This wave is called the carrier. For fiber optic system, a laser diode (LD) or a light emitting diode (LED) is used. They can be called as optic oscillators, they provide stable, single frequency waves with sufficient power for long distance propagation.

Channel coupler:

Coupler feeds the power into information channel. For an atmospheric optic system, the channel coupler is a lens used for collimating the light emitted by the source and directing this light towards the receiver. The coupler must efficiently transfer the modulated light beam from the source to the optic fiber. The channel coupler design is an important part of fiber system because of possibility of high losses.

Information channel:

The information channel is the path between the transmitter and receiver. In fiber optic communications, a glass or plastic fiber is the channel. Desirable characteristics of the information channel include low attenuation and large light acceptance cone angle. Optical amplifiers boost the power levels of weak signals. Amplifiers are needed in very long links to provide sufficient power to the receiver. Repeaters can be used only for digital systems. They convert weak and distorted optical signals to electrical ones and then regenerate the original digital pulse trains for further transmission.

Another important property of the information channel is the propagation time of the waves travelling along it. A signal propagating along a fiber normally contains a range of fiber optic frequencies and divides its power along several ray paths. This results in a distortion of the propagation signal. In a digital system, this distortion appears as a spreading and deforming of the pulses. The spreading is so great that adjacent pulses begin to overlap and become unrecognizable as separate bits of information.

Optical detector:

The information being transmitted is detected by detector. In the fiber system the optic wave is converted into an electric current by a photodetector. The current developed by the detector is proportional to the power in the incident optic wave. Detector output current contains the transmitted information. This detector output is then filtered to remove the constant bias and then amplified. The important properties of photodetectors are small size, economy, long life, low power consumption, high sensitivity to optic signals and

fast response to quick variations in the optic power. Signal processing includes filtering, amplification

Signal processing:

Signal processing includes filtering, amplification. Proper filtering maximizes the ratio of signal to unwanted power. For a digital system decision circuit is an additional block. The bit error rate (BER) should be very small for quality communications.

Message output:

The electrical form of the message emerging from the signal processor is transformed into a sound wave or visual image. Sometimes these signals are directly usable when computers or other machines are connected through a fiber system.

Electromagnetic Spectrum

The radio waves and light are electromagnetic waves. The rate at which they alternate in polarity is called their frequency (f) measured in hertz (Hz). The speed of electromagnetic wave (c) in free space is approximately 3×10^8 m/sec. The distance travelled during each cycle is called as wavelength (λ)

Fiber optics uses visible and infrared light. Infrared light covers a fairly wide range of wavelengths and is generally used for all fiber optic communications. Visible light is normally used for very short range transmission using a plastic fiber

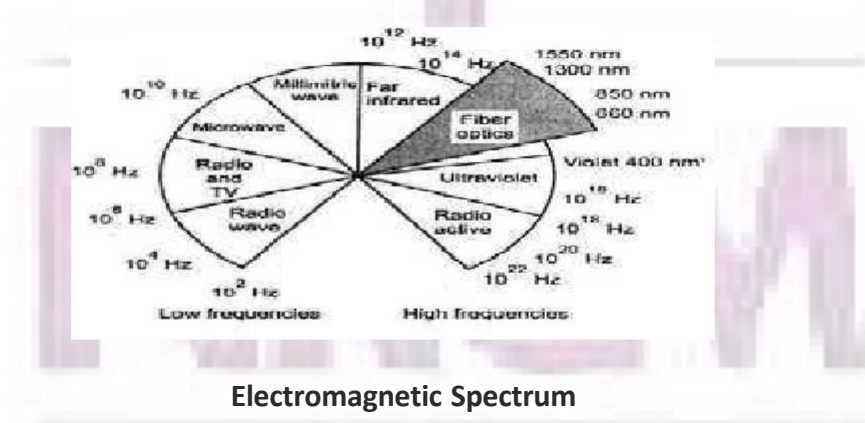

Electromagnetic Spectrum

Optical Fiber Waveguides

In free space light travels at its maximum possible speed i.e. 3×10^8 m/s or 186×10^3 miles/sec. When light travels through a material it exhibits certain behavior explained by

laws of reflection, refraction. An optical wave guide is a structure that "guides" a light wave by constraining it to travel along a certain desired path. If the transverse dimensions of the guide are much larger than the wavelength of the guided light, that explain how the optical waveguide works using geometrical optics and total internal reflection.

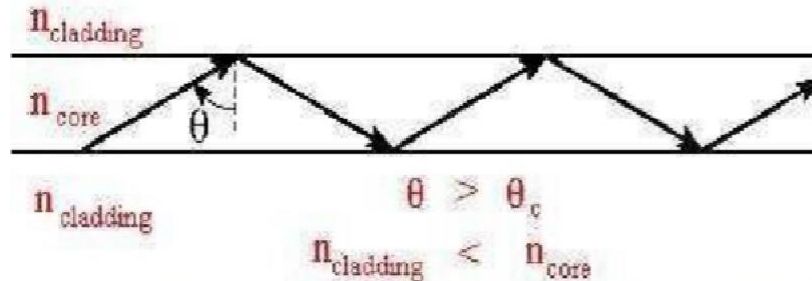

A wave guide traps light by surrounding a guiding region, called the core, made from a material with index of refraction n_{core} , with a material called the cladding, made from a material with index of refraction $n_{\text{cladding}} < n_{\text{core}}$. Light entering is trapped as long as $\sin\theta > n_{\text{cladding}}/n_{\text{core}}$.

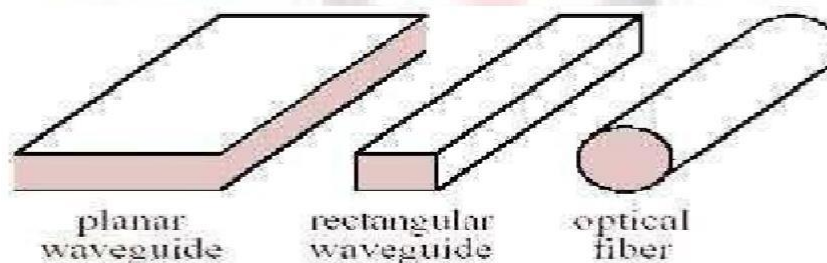

Light can be guided by planar or rectangular wave guides, or by optical fibers. An optical fiber consists of three concentric elements, the core, the cladding and the outer coating, often called the buffer. The core is usually made of glass or plastic. The core is the light-carrying portion of the fiber. The cladding surrounds the core. The cladding is made of a material with a slightly lower index of refraction than the core. This difference in the indices causes total internal reflection to occur at the core-cladding boundary along the length of the fiber. Light is transmitted down the fiber and does not escape through the sides of the fiber.

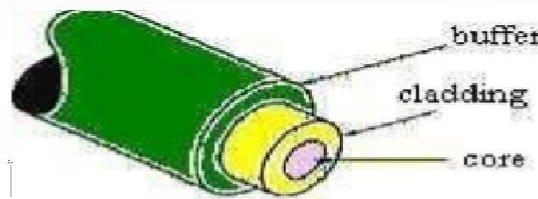

Fiber Optic Core: the inner light-carrying member with a high index of refraction.

Cladding: the middle layer, which serves to confine the light to the core. It has a lower index of refraction.

Buffer: The outer layer, which serves as a "shock absorber" to protect the core and cladding from damage. The coating usually comprises one or more coats of a plastic material to protect the fiber from the physical environment.

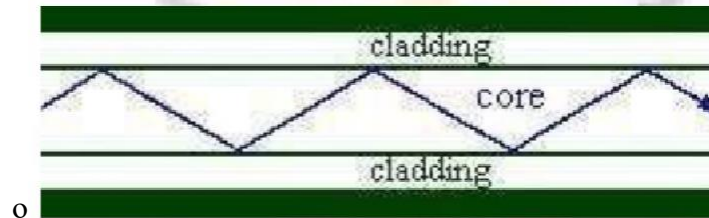

Light injected into the fiber optic core and striking the core-to-cladding interface at an angle greater than the critical angle is reflected back into the core. Since the angles of incidence and reflection are equal, the light ray continues to zigzag down the length of the fiber. The light is trapped within the core. Light striking the interface at less than the critical angle passes into the cladding and is lost.

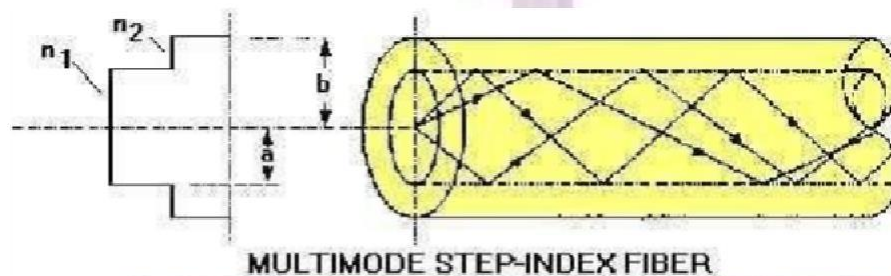

Fibers for which the refractive index of the core is a constant and the index changes abruptly at the core-cladding interface are

called step-index fibers. Step-index fibers are available with core diameters of 100 μm to 1000 μm . They are well suited to applications requiring high-power densities, such as delivering laser power for medical and industrial applications.

Multimode step-index fibers trap light with many different entrance angles, each mode in a step-index multimode fiber is associated with a different entrance angle. Each mode therefore travels along a different path through the fiber. Different propagating modes have different velocities. As an optical pulse travels down a multimode fiber, the pulse begins to spread. Pulses that enter well separated from each other will eventually overlap each

other. This limits the distance over which the fiber can transport data. Multimode step-index fibers are not well suited for data transport and communications.

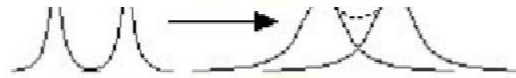

In a multimode graded-index fiber the core has an index of refraction that decreases as the radial distance from the center of the core increases. As a result, the light travels faster near the edge of the core than near the center. Different modes therefore travel in curved paths with nearly equal travel times. This greatly reduces the spreading of optical pulses.

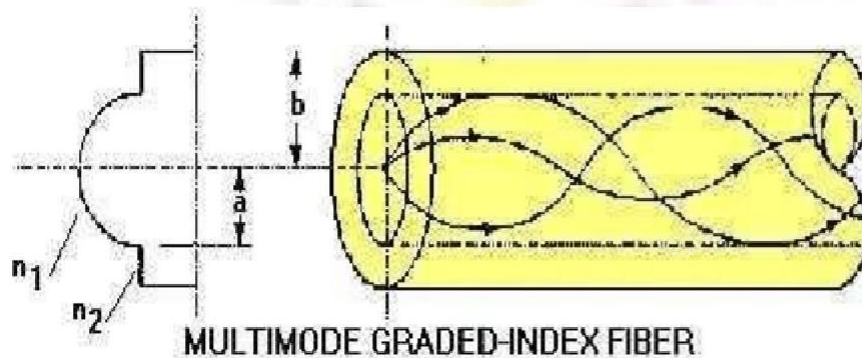

A single mode fiber only allows light to propagate down its center and there are no longer different velocities for different modes. A single mode fiber is much thinner than a multimode fiber and can no longer be analyzed using geometrical optics. Typical core diameters are between 5 mm and 10 mm.

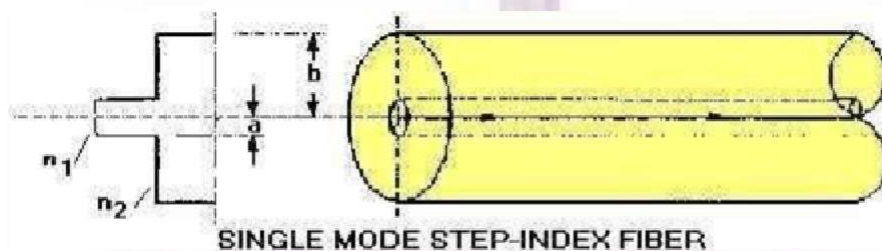

When laser light is coupled into a fiber, the distribution of the light emerging from the other end reveals if the fiber is a multimode or single mode fiber.

Ray theory

The phenomenon of splitting of white light into its constituents is known as dispersion. The concepts of reflection and refraction of light are based on a theory known as Ray theory or geometric optics, where light waves are considered as waves and represented with simple geometric lines or rays.

The basic laws of ray theory/geometric optics

- ❖ In a homogeneous medium, light rays are straight lines.
- ❖ Light may be absorbed or reflected.
- ❖ Reflected ray lies in the plane of incidence and angle of incidence will be equal to the angle of reflection.
- ❖ At the boundary between two media of different refractive indices, the refracted ray will lie in the plane of incidence. Snell's Law will give the relationship between the angles of incidence and refraction.

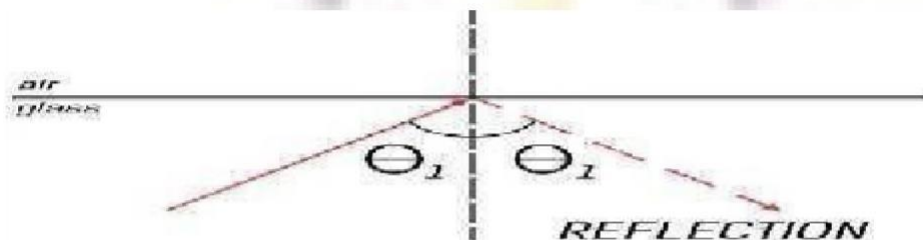

Reflection depends on the type of surface on which light is incident. An essential condition for reflection to occur with glossy surfaces is that the angle made by the incident ray of light with the normal at the point of contact should be equal to the angle of reflection with that normal. The images produced from this reflection have different properties according to the shape of the surface. For example, for a flat mirror, the image produced is upright, has the same size as that of the object and is equally distanced from the surface of the mirror as the real object. However, the properties of a parabolic mirror are different and so on.

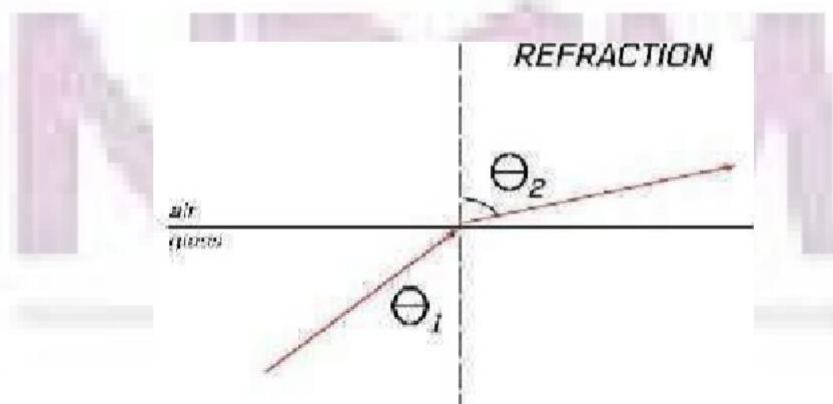

Refraction is the bending of light in a particular medium due to the speed of light in that medium. The speed of light in any medium can be given by

$$v = \frac{c}{n}$$

$$\text{Refractive index } n = \frac{\text{Speed of light in air}}{\text{Speed of light in medium}} = \frac{c}{v}$$

The refractive index for vacuum and air is 1.0 for water it is 1.3 and for glass refractive index is 1.5. Here n is the refractive index of that medium. When a ray of light is incident at the interface of two media with different refractive indices, it will bend either towards or away from the normal depending on the refractive indices of the media. According to Snell's law, refraction can be represented as

$$n_1 \sin(\theta_1) = n_2 \sin(\theta_2)$$

n_1 = refractive index of first medium

θ_1 = angle of incidence, n_2 = refractive index of second medium

θ_2 = angle of refraction

For $n_1 > n_2$, θ_1 is always greater than θ_2 . Or to put it in different words, light moving from a medium of high refractive index (glass) to a medium of lower refractive index (air) will move away from the normal.

Total internal reflection

To consider the propagation of light within an optical fiber utilizing the ray theory model it is necessary to take account of the refractive index of the dielectric medium. Optical materials are characterized by their index of refraction, referred to as n . The refractive index of a medium is defined as the ratio of the velocity of light in a vacuum to the velocity of light in the medium.

When a beam of light passes from one material to another with a different index of refraction, the beam is bent (or refracted) at the interface.

$$n_i \sin I = n_r \sin R$$

where n_i and n_r are the indices of refraction of the materials through which the beam is refracted and I and R are the angles of incidence and refraction of the beam. If the angle of incidence is greater than the critical angle for the interface (typically about 82° for optical fibers), the light is reflected back into the incident medium without loss by a process known as total internal reflection.

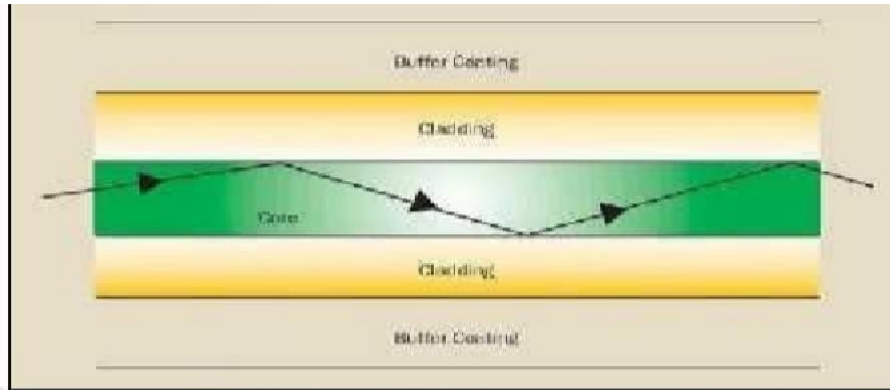

Figure Total Internal Reflection allows light to remain inside the core of the fiber

Refraction is described by Snell's law:

A ray of light travels more slowly in an optically dense medium than in one that is less dense, and the refractive index gives a measure of this effect. When a ray is incident on the interface between two dielectrics of differing refractive indices (e.g. glass-air), refraction occurs, as illustrated in Figure . It may be observed that the ray approaching the interface is propagating in a dielectric of refractive index n_1 and is at an angle ϕ_1 to the normal at the surface of the interface.

If the dielectric on the other side of the interface has a refractive index n_2 which is less than n_1 , then the refraction is such that the ray path in this lower index medium is at an angle to the normal, where is greater than ϕ_1 . The angles of incidence and refraction are related to each other and to the refractive indices of the dielectrics by Snell's law of refraction, which states that:

$$n_1 \sin \phi_1 = n_2 \sin \phi_2$$

Or

$$\frac{\sin \phi_1}{\sin \phi_2} = \frac{n_2}{n_1}$$

It may also be observed in Figure that a small amount of light is reflected back into the originating dielectric medium (partial internal reflection). As n_1 is greater than n_2 , the angle of refraction is always greater than the angle of incidence. Thus when the angle of refraction is 90° and the refracted ray emerges parallel to the interface between the dielectrics, the angle of incidence must be less than 90° .

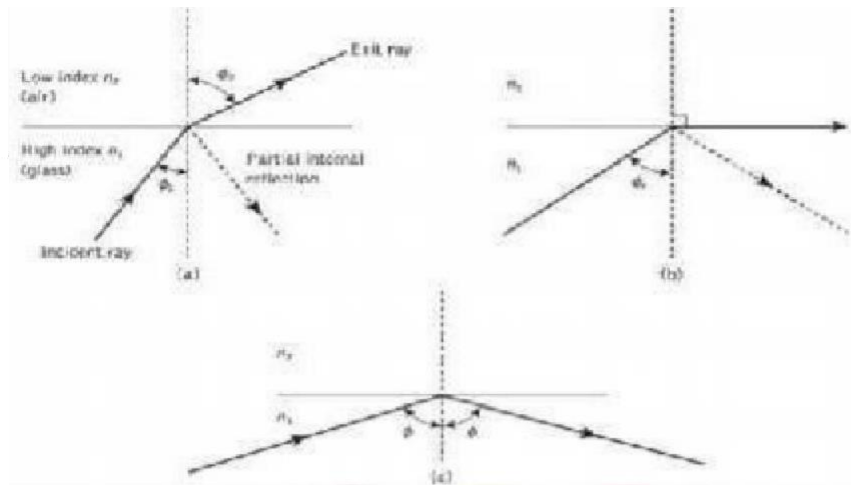

Figure Light rays incident on a high to low refractive index

This is the limiting case of refraction and the angle of incidence is now known as the critical angle ϕ_c , as shown in Figure. The value of the critical angle is given by

$$\sin \phi_c = \frac{n_2}{n_1}$$

At angles of incidence greater than the critical angle the light is reflected back into the originating dielectric medium (total internal reflection) with high efficiency (around 99.9%). Hence, it may be observed in Figure that total internal reflection occurs at the interface between two dielectrics of differing refractive indices when light is incident on the dielectric of lower index from the dielectric of higher index, and the angle of incidence of the ray exceeds the critical value. This is the mechanism by which light at a sufficiently shallow angle (less than 90°) may be considered to propagate down an optical fiber with low loss.

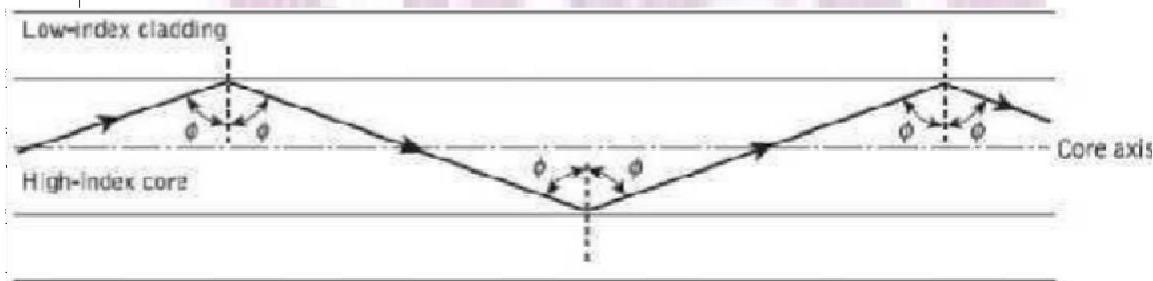

Figure Transmission of a light ray in a perfect optical fiber

The above figure illustrates the transmission of a light ray in an optical fiber via a series of total internal reflections at the interface of the silica core and the slightly lower refractive index silica cladding. The ray has an angle of incidence ϕ at the interface which is greater than the critical angle and is reflected at the same angle to the normal. The light ray shown

in Figure is known as a meridional ray as it passes through the axis of the fiber core. This type of ray is the simplest to describe and is generally used when illustrating the fundamental transmission properties of optical fibers.

It must also be noted that the light transmission illustrated in Figure assumes a perfect fiber, and that any discontinuities or imperfections at the core-cladding interface would probably result in refraction rather than total internal reflection, with the subsequent loss of the light ray into the cladding.

Critical Angle

When the angle of incidence is progressively increased, there will be progressive increase of refractive angle. At some condition the refractive angle becomes 90° to the normal. When this happens the refracted light ray travels along the interface. The angle of incidence at the point at which the refractive angle becomes 90° is called the critical angle. The critical angle is defined as the minimum angle of incidence at which the ray strikes the interface of two media and causes an angle of refraction equal to 90° . Figure shows critical angle refraction. When the angle of refraction is 90 degree to the normal the refracted ray is parallel to the interface between the two media. Using Snell's law

$$\sin \phi_c = \frac{n_2}{n_1} \sin 90^\circ$$

$$\sin 90^\circ = 1$$

$$\text{Critical angle } \phi_c = \sin^{-1} \left(\frac{n_2}{n_1} \right)$$

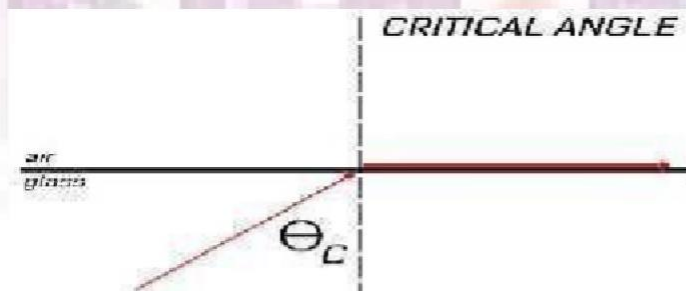

It is important to know about this property because reflection is also possible even if the surfaces are not reflective. If the angle of incidence is greater than the critical angle for a given setting, the resulting type of reflection is called Total Internal Reflection, and it is the basis of Optical Fiber Communication.

Acceptance angle

In an optical fiber, a light ray undergoes its first refraction at the air-core interface. The angle at which this refraction occurs is crucial because this particular angle will dictate whether the subsequent internal reflections will follow the principle of Total Internal Reflection. This angle, at which the light ray first encounters the core of an optical fiber is called Acceptance angle.

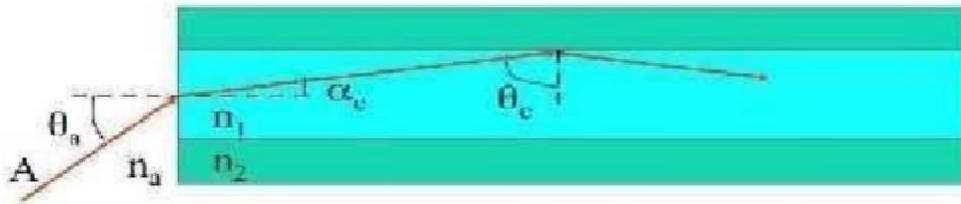

The objective is to have θ_a greater than the critical angle for this particular setting. As you can notice, θ_a depends on the orientation of the refracted ray at the input of the optical fiber. This in turn depends on θ_c , the acceptance angle. The acceptance angle can be calculated with the help of the formula below.

Numerical Aperture

Numerical Aperture is a characteristic of any optical system. For example, photo-detector, optical fiber, lenses etc. are all optical systems. Numerical aperture is the ability of the optical system to collect the entire light incident on it, in one area. The blue cone is known as the cone of acceptance. As you can see it is dependent on the Acceptance Angle of the optical fiber. Light waves within the acceptance cone can be collected in a small area which can then be sent into the optical fiber (Source).

Numerical aperture (NA), shown in above Figure, is the measure of maximum angle at which light rays will enter and be conducted down the fiber. This is represented by the following equation:

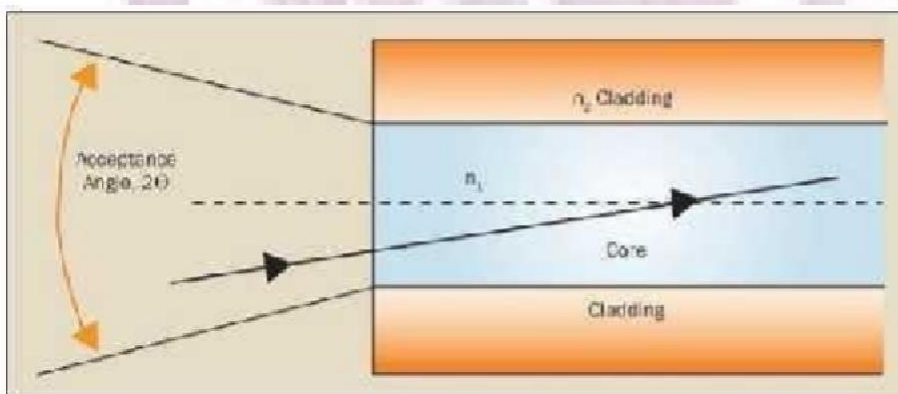

$$NA = \sqrt{(n_{core}^2 - n_{cladding}^2)} = \sin \theta$$

Skew rays: In a multimode optical fiber, a bound ray that travels in a helical path along the fiber and thus (a) is not parallel to the fiber axis, (b) does not lie in a meridional plane, and (c) does not intersect the fiber axis is known as a Skew Ray.

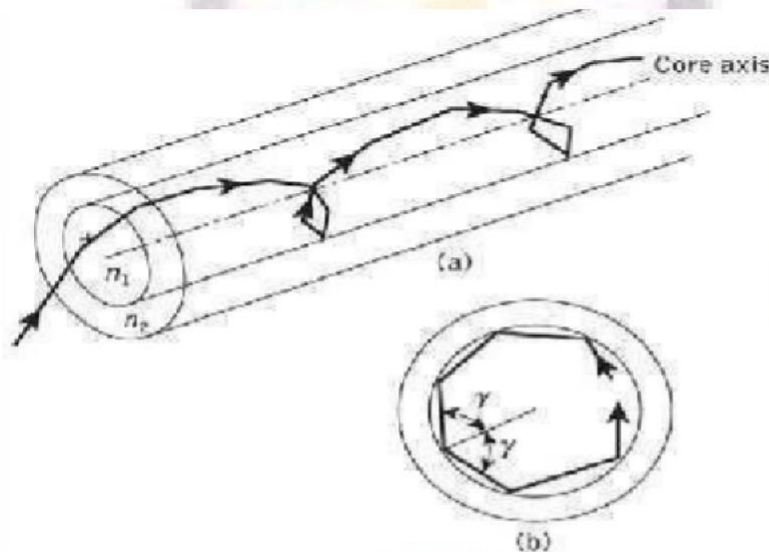

Figure, view (a), provides an angled view and view (b) provides a front view.

1. Skew rays are rays that travel through an optical fiber without passing through its axis.
2. A possible path of propagation of skew rays is shown in figure.
3. Skew rays are those rays which follow helical path but they are not confined to a single plane. Skew rays are not confined to a particular plane so they cannot be tracked easily. Analyzing the meridional rays is sufficient for the purpose of result, rather than skew rays, because skew rays lead to greater power loss.
4. Skew rays propagate without passing through the center axis of the fiber. The acceptance angle for skew rays is larger than the acceptance angle of meridional rays.
5. Skew rays are often used in the calculation of light acceptance in an optical fiber. The addition of skew rays increases the amount of light capacity of a fiber. In large NA fibers, the increase may be significant.
6. The addition of skew rays also increases the amount of loss in a fiber. Skew rays tend to

propagate near the edge of the fiber core. A large portion of the number of skew rays that are trapped in the fiber core are considered to be leaky rays.

7. Leaky rays are predicted to be totally reflected at the core-cladding boundary. However, these rays are partially refracted because of the curved nature of the fiber boundary. Mode theory is also used to describe this type of leaky ray loss.

Attenuation

Attenuation is a measure of decay of signal strength or loss of light power that occurs as light pulses propagate through the length of the fiber. In optical fibers the attenuation is mainly caused by two physical factors absorption and scattering losses. Absorption is because of fiber material and scattering due to structural imperfection within the fiber. Nearly 90% of total attenuation is caused by Rayleigh scattering only. Microbending of optical fiber also contributes to the attenuation of signal.

The rate at which light is absorbed is dependent on the wavelength of the light and the characteristics of particular glass. Glass is a silicon compound, by adding different additional chemicals to the basic silicon dioxide the optical properties of the glass can be changed.

The Rayleigh scattering is wavelength dependent and reduces rapidly as the wavelength of the incident radiation increases. The attenuation of fiber is governed by the materials from which it is fabricated, the manufacturing process and the refractive index profile chosen. Attenuation loss is measured in dB/km.

Attenuation Units

As attenuation leads to a loss of power along the fiber, the output power is significantly less than the couples power. Let the couples optical power is $p(0)$ i.e. at origin ($z = 0$). Then the power at distance z is given by,

$$P(z) = P(0)e^{-\alpha_p z}$$

where, α_p is fiber attenuation constant (per km).

$$\alpha_p = \frac{1}{z} \ln \left[\frac{P(0)}{P(z)} \right]$$

$$\alpha_{dB/km} = 10 \cdot \frac{1}{z} \log \left[\frac{P(0)}{P(z)} \right]$$

$$\alpha_{dB/km} = 4.343 \alpha_p \text{ per km}$$

This parameter is known as fiber loss or fiber attenuation. Attenuation is also a function of wavelength. Optical fiber wavelength as a function of wavelength is shown in Figure.

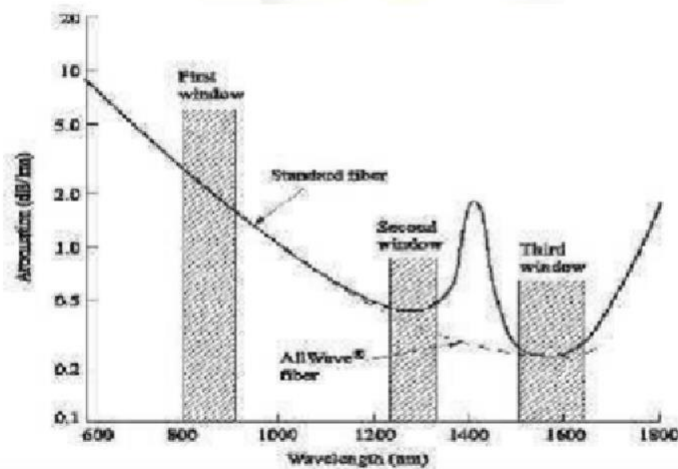

Optical fiber attenuation as a function of wavelength yields nominal values of 0.5 dB/km at 1310 nm and 0.3 dB/km at 1550 nm for standard single mode fiber. Absorption by the water molecules causes the attenuation peak around 1100nm for standard fiber. The dashed curve is the attenuation for low water peak fiber.

Figure Optical fiber wavelength as a function of wavelength

Absorption

Absorption loss is related to the material composition and fabrication process of fiber. Absorption loss results in dissipation of some optical power as heat in the fiber cable. Although glass fibers are extremely pure, some impurities still remain as residue after purification. The amount of absorption by these impurities depends on their concentration and light wavelength.

Absorption in optical fiber is caused by these three mechanisms.

1. Absorption by atomic defects in the glass composition
2. Extrinsic absorption by impurity atoms in the glass material
3. Intrinsic absorption by the basic constituent atoms of the fiber material.

Absorption by Atomic Defects

Atomic defects are imperfections in the atomic structure of the fiber materials such as missing molecules, high density clusters of atom groups. These absorption losses are

negligible compared with intrinsic and extrinsic losses.

The absorption effect is most significant when fiber is exposed to ionizing radiation in nuclear reactor, medical therapies, space missions etc. The radiation damages the internal structure of fiber. The damages are proportional to the intensity of ionizing particles. This results in increasing attenuation due to atomic defects and absorbing optical energy. The total dose a material receives is expressed in rad (Si), this is the unit for measuring radiation absorbed in bulk silicon. $1 \text{ rad (Si)} = 0.01 \text{ J/kg}$. The higher the radiation intensity more the attenuation as shown in Figure

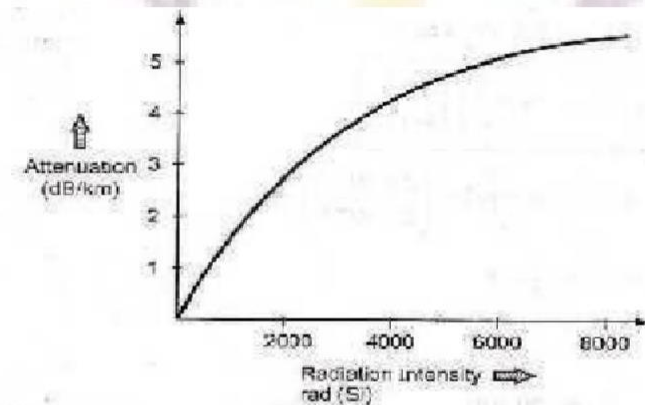

Figure ionizing radiation intensity vs fiber attenuation

Extrinsic Absorption

Extrinsic absorption occurs due to electronic transitions between the energy level and because of charge transitions from one ion to another. A major source of attenuation is from transition of metal impurity ions such as iron, chromium, cobalt and copper. These losses can be upto 1 to 10 dB/km. The effect of metallic impurities can be reduced by glass refining techniques. Another major extrinsic loss is caused by absorption due to OH (Hydroxyl) ions impurities dissolved in glass. Vibrations occur at wavelengths between 2.7 and 4.2 μm . The absorption peaks occur at 1400, 950 and 750 nm. These are first, second and third overtones respectively. Figure shows absorption spectrum for OH group in silica. Between these absorption peaks there are regions of low attenuation.

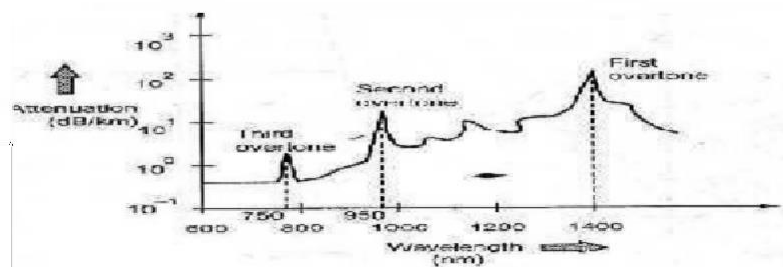

Figure Absorption spectra for OH groups

Intrinsic Absorption

Intrinsic absorption occurs when material is in absolutely pure state, no density variation and in homogeneities. Thus intrinsic absorption sets the fundamental lower limit on absorption for any particular material. Intrinsic absorption results from electronic absorption bands in UV region and from atomic vibration bands in the near infrared region. The electronic absorption bands are associated with the band gaps of amorphous glass materials. Absorption occurs when a photon interacts with an electron in the valence band and excites it to a higher energy level. UV absorption decays exponentially with increasing wavelength (λ). In the IR (infrared) region above 1.2 μm the optical waveguide loss is determined by presence of the OH ions and inherent IR absorption of the constituent materials.

The inherent IR absorption is due to interaction between the vibrating band and the electromagnetic field of optical signal this results in transfer of energy from field to the band, thereby giving rise to absorption, this absorption is strong because of many bonds present in the fiber. The ultraviolet loss at any wavelength is expressed as,

$$\alpha_{\text{UV}} = \frac{154.2}{46.6x+60} \times 10^{-2} \times e^{\left(\frac{4.65}{\lambda}\right)}$$

where, x is mole fraction of GeO_2 . λ is operating wavelength. α_{UV} is in

dB/km. The loss in infrared (IR) region (above 1.2 μm) is given by

expression

The expression is derived for GeO_2 - SiO_2 glass fiber.

$$\alpha_{\text{IR}} = 7.81 \times 10^{11} \times e^{\left(\frac{7.05 \times 10^5}{\lambda}\right)}$$

Rayleigh Scattering Losses

Scattering losses exists in optical fibers because of microscopic variations in the material density and composition. As glass is composed by randomly connected network of molecules and several oxides (e.g. SiO_2 , GeO_2 and P_2O_5), these are the major cause of compositional structure fluctuation. These two effects results to variation in refractive index

and Rayleigh type scattering of light.

Rayleigh scattering of light is due to small localized changes in the refractive index of the core and cladding material. There are two causes during the manufacturing of fiber. The first is due to slight fluctuation in mixing of ingredients. The random changes because of this are impossible to eliminate completely. The other cause is slight change in density as the silica cools and solidifies. When light ray strikes such zones it gets scattered in all directions. The amount of scatter depends on the size of the discontinuity compared with the wavelength of the light so the shortest wavelength (highest frequency) suffers most scattering. The below figure shows graphically the relationship between wavelength and Rayleigh scattering loss.

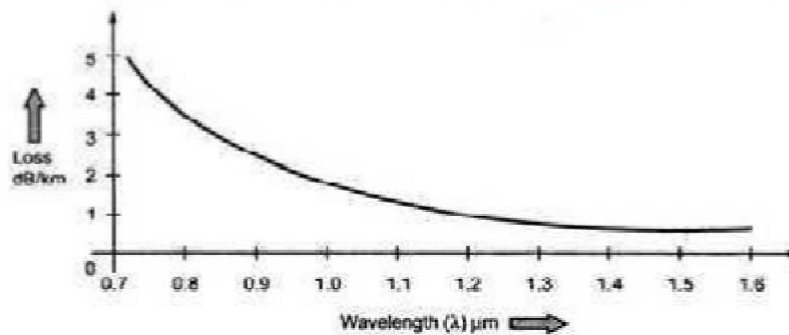

Figure Scattering loss

Scattering loss for single component glass is given by,

$$\alpha_{\text{scat}} = \frac{8\pi^4}{3\lambda^4} (n^2 - 1)^2 k_B T_f \beta_T \text{ nepers}$$

where, n = Refractive index, B = Boltzmann's constant, β_T = Isothermal compressibility of material, T_f = Temperature at which density fluctuations are frozen into the glass as it solidifies (fictive temperature)

Another form of equation is

$$\alpha_{\text{scat}} = \frac{8\pi^3}{3\lambda^4} n^0 p^2 k_B T_f \beta_T \text{ nepers} \quad \alpha_{\text{scat}} = \frac{8\pi^3}{3\lambda^4} (\delta_n^2)^2 \delta v$$

where, P = Photoelastic coefficient

where, δ_n^2 = Mean square refractive index fluctuation

δv = Volume of fiber

Multimode fibers have higher dopant concentrations and greater compositional fluctuations.

The overall losses in these fibers are more as compared to single mode fibers.

Mie Scattering

Linear scattering also occurs at in homogenities and these arise from imperfections in the fiber's geometry, irregularities in the refractive index and the presence of bubbles etc. caused during manufacture. Careful control of manufacturing process can reduce Mie scattering to insignificant levels.

Bending Loss

Radiative losses occur whenever an optical fiber undergoes a bend of finite radius of curvature. Fibers can be subjected to two types of bends:

- a) Macroscopic bends (having radii that are large as compared with the fiber diameter)
- b) Random microscopic bends of fiber axis Losses due to curvature and losses caused by an abrupt change in radius of curvature are referred to as 'bending losses.' The sharp bend of a fiber causes insignificant radiative losses and there is also possibility of mechanical failure.

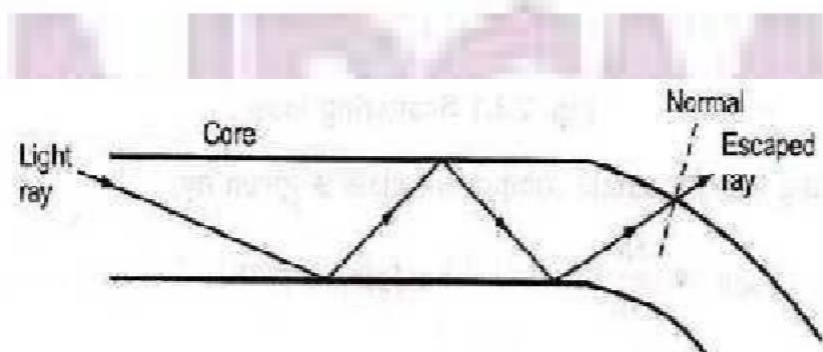
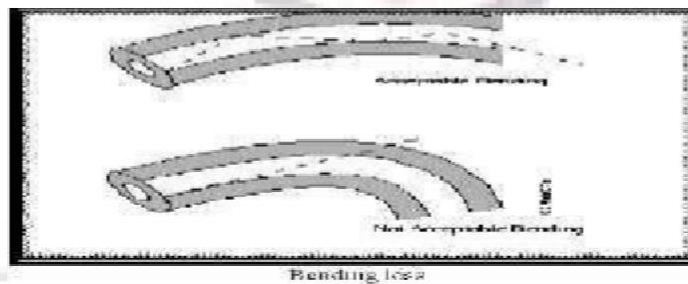

As the core bends the normal will follow it and the ray will now find itself on the wrong side of critical angle and will escape. The sharp bends are therefore avoided. The radiation loss from a bent fiber depends on –Field strength of certain critical distance x_c from fiber axis where power is lost through radiation.

The radius of curvature R.

The higher order modes are less tightly bound to the fiber core, the higher order modes radiate out of fiber firstly. For multimode fiber, the effective number of modes that can be guided by curved fiber is

where, α is graded index profile.

Δ is core – cladding index difference. n_2 is refractive index of cladding, k is wave propagation constant $\left(\frac{2\pi}{\lambda}\right)$.

$$N_{\infty} = \frac{\alpha}{\alpha+2} (n_1 k a)^2 l$$

N_{∞} is total number of modes in a straight fiber.

Micro bending Loss

Another form of radiation loss in optical waveguide results from mode coupling caused by random micro bends of the optical fiber. Micro bends are repetitive small scale fluctuations in the radius of curvature of the fiber axis. They are caused either by non uniformities in the manufacturing of the fiber or by non uniform lateral pressures created during the cabling of the fiber. An increase in attenuation results from micro bending because the fiber curvature causes repetitive coupling of energy between the guided modes and the leaky or non guided modes in the fiber.

Micro bending losses can be minimized by placing a compressible jacket over the fiber. When external forces are applied to this configuration, the jacket will be deformed but the fiber will tend to stay relatively straight. Microbending is a loss due to small bending or distortions. This small microbending is not visible. The losses due to this are temperature related, tensile related or crush related.

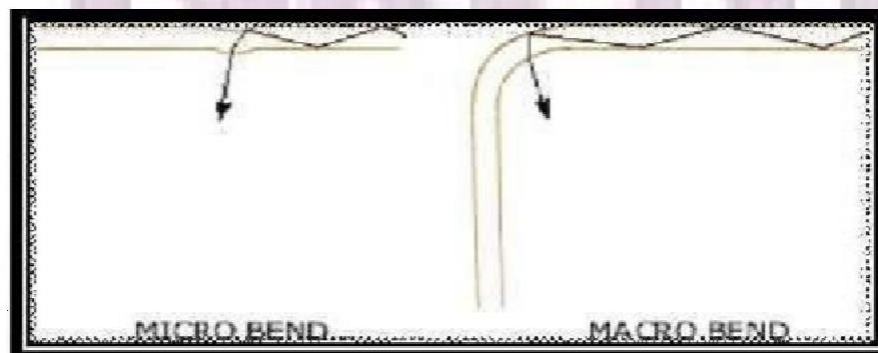

Macrobending

ng on wavelength) to a series of periodic peaks and trou
 on curve. These effects can be minimized during insta
 lustrates microbending.

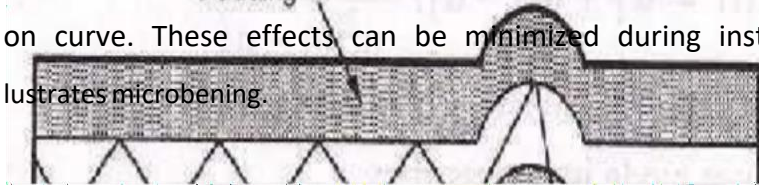

For slight bends, the loss is extremely small and is not observed. As the radius of curvature decreases, the loss increases exponentially until at a certain critical radius of curvature loss becomes observable. If the bend radius is made a bit smaller once this threshold point has been reached, the losses suddenly become extremely large. It is known that any bound core mode has an evanescent field tail in the cladding which decays exponentially as a function of distance from the core. Since this field tail moves along with the field in the core, part of the energy of a propagating mode travels in the fiber cladding. When a fiber is bent, the field tail on the far side of the centre of curvature must move faster to keep up with the field in the core, for the lowest order fiber mode.

At a certain critical distance x_c , from the centre of the fiber; the field tail would have to move faster than the speed of light to keep up with the core field. Since this is not possible the optical energy in the field tail beyond x_c radiates away.

The amount of optical radiation from a bent fiber depends on the field strength at x_c and on the radius of curvature R . Since higher order modes are bound less tightly to the fiber core than lower order modes, the higher order modes will radiate out of the fiber first. The change in spectral attenuation caused by macrobending is different to microbending. Usually there are no peaks and troughs because in a macrobending no light is coupled back into the core from the cladding as can happen in the case of microbends. The macrobending losses are caused by large scale bending of fiber. The losses are eliminated when the bends are straightened. The losses can be minimized by not exceeding the long term bend radii.

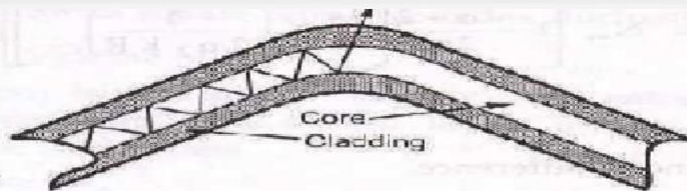

Figure macrobending loss

Core and Cladding Loss

Since the core and cladding have different indices of refraction hence they have different attenuation coefficients α_1 and α_2 respectively.

$$\alpha(r) = \alpha_1 + (\alpha_2 - \alpha_1) \frac{n^2(0) - n^2(r)}{n^2(0) - n^2_2}$$

For step index fiber, the loss for a mode order (v, m) is given by,

$$\alpha_{vm} = \alpha_1 \frac{P_{core}}{P} + \alpha_2 \frac{P_{cladding}}{P} \dots$$

For low-order modes, the expression reduced to

$$\alpha_{vm} = \alpha_1 + (\alpha_2 - \alpha_1) \frac{P_{cladding}}{P} \dots$$

where, $\frac{P_{core}}{P}$ and $\frac{P_{cladding}}{P}$ are fractional powers.

For graded index fiber, loss at radial distance is expressed

as, The loss for a given mode is expressed by,

$$\alpha_{Graded\ Index} = \frac{\int_0^\infty \alpha(r) P(r) r dr}{\int_0^\infty P(r) r dr} \quad \text{where, } P(r) \text{ is power density of that mode at radial distance } r.$$

Laser Diodes (LD)

Characteristics of Light Source of Communication

To be useful in an optical link, a light source needs the following characteristics It must be possible to operate the device continuously at a variety of temperatures for many years. It must be possible to modulate the light output over a wide range of modulating frequencies. For fiber links, the wavelength of the output should coincide with one of transmission windows for the fiber type used. To couple large amount of power into an optical fiber, the emitting area

should be small. To reduce material dispersion in an optical fiber link, the output spectrum should be narrow. The power requirement for its operation must be low. The light source must be compatible with the modern solid state devices. The optical output power must be directly modulated by varying the input current to the device. Better linearity of prevent harmonics and intermodulation distortion. High coupling efficiency. High optical output power. High reliability. Low weight and low cost.

Two types of light sources used in fiber optics are light emitting diodes (LEDs) and laser diodes (LDs).

Light Emitting Diodes

(LEDs)p-n Junction

Conventional p-n junction is called as homojunction as same semiconductor material is used on both sides junction. The electron-hole recombination occurs in relatively layer = 10 μm . As the carriers are not confined to the immediate vicinity of junction, hence high current densities cannot be realized. The carrier confinement problem can be resolved by sandwiching a thin layer (= 0.1 μm) between p-type and n-type layers. The middle layer may or may not be doped. The carrier confinement occurs due to band gap discontinuity of the junction. Such a junction is called as heterojunction and the device is called double heterostructure.

In any optical communication system when the requirements is

1. Bit rate of 100-2—Mb/sec.
2. Optical power in tens of micro watts, LEDs are best suitable optical source.

LED

Structures

Heterojunctions

ns:

A heterojunction is an interface between two adjoining single crystal semiconductors with different band gap. Heterojunctions are of two types, Isotype (n-n or p-p) or Antistype (p-n).

Double Heterojunctions (DH):

In order to achieve efficient confinement of emitted radiation double heterojunction are used in LED structure. A heterojunction is a junction formed by dissimilar semiconductors. Double heterojunction (DH) is formed by two different semiconductors on each side of active

region. Figure shows double heterojunction (DH) light emitter.

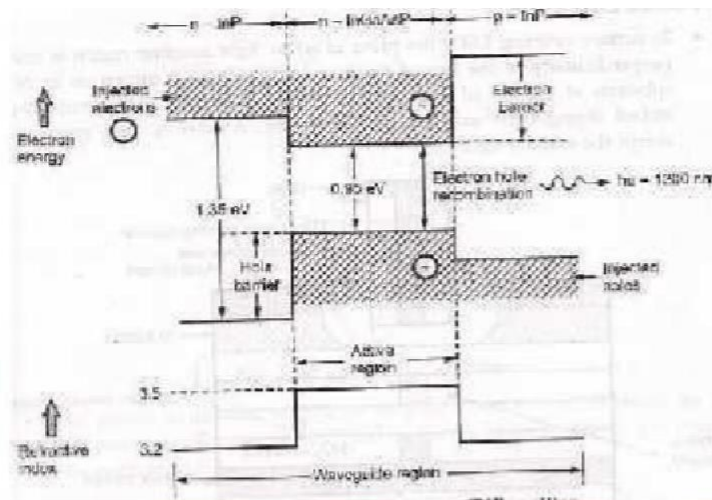

The crosshatched regions represent the energy levels of free charge. Recombination occurs only in active In GaAsP layer. The two materials have different band gap energies and different refractive indices. The changes in band gap energies create potential barrier for both holes and electrons. The free charges can recombine only in narrow, well defined active layer side.

A double heterojunction (DH) structure will confine both hole and electrons to a narrow active layer. Under forward bias, there will be a large number of carriers injected into active region where they are efficiently confined. Carrier recombination occurs in small active region so leading to an efficient device. Another advantage DH structure is that the active region has a higher refractive index than the materials on either side, hence light emission occurs in an optical waveguide, which serves to narrow the output beam.

LED configurations

At present there are two main types of LED used in optical fiber links

- ❖ Surface emitting LED
- ❖ Edge emitting LED.

Both devices used a DH structure to constrain the carriers and the light to an active layer.

Surface Emitting LEDs

In surface emitting LEDs the plane of active light emitting region is oriented perpendicularly to the axis of the fiber. A DH diode is grown on an N-type substrate at the top of the diode as shown in Figure. A circular well is etched through the substrate of the device. A fiber is then connected to accept the emitted

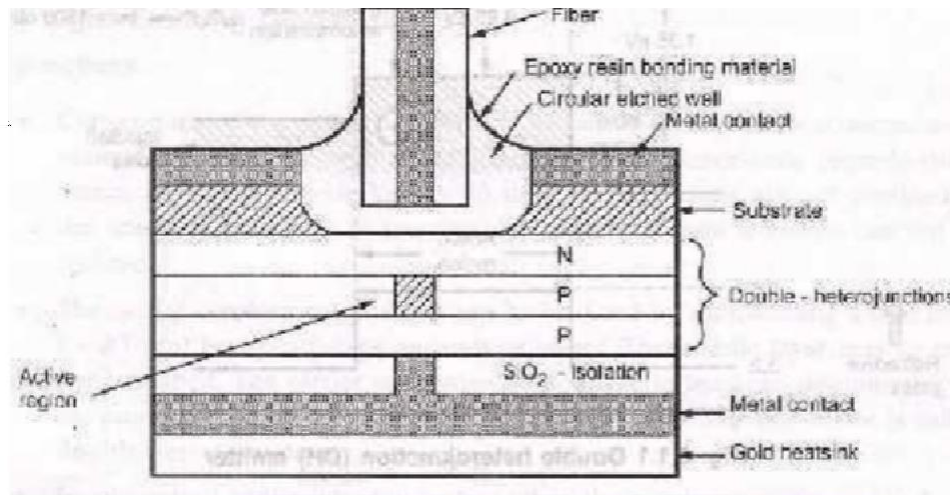

Figure Cross section through a typical surface emitting LED

At the back of device is a gold heat sink. The current flows through the p-type material and forms the small circular active region resulting in the intense beam of light.

Diameter of circular active area = $50 \mu\text{m}$

Thickness of circular active area = $2.5 \mu\text{m}$

Current density = 2000 A/cm^2 half-power

Emission pattern = Isotropic, 120° beamwidth.

The isotropic emission pattern from surface emitting LED is of Lambertian pattern. In Lambertian pattern, the emitting surface is uniformly bright, but its projected area diminishes as $\cos \theta$, where θ is the angle between the viewing direction and the normal to the surface as shown in Figure. The beam intensity is maximum along the normal.

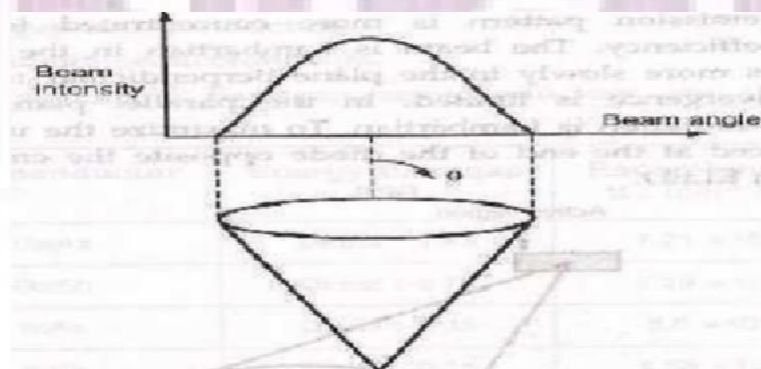

Figure Lambertian radiation

The power is reduced to 50% of its peak when $\theta = 60^\circ$, therefore the total half-power beamwidth is 120° . The radiation pattern decides the coupling efficiency of LED.

Edge Emitting LEDs (ELEDs)

In order to reduce the losses caused by absorption in the active layer and to make the beam more directional, the light is collected from the edge of the LED. Such a device is known as edge emitting LED or ELED. It consists of an active junction region which is the source of incoherent light and two guiding layers. The refractive index of guiding layers is lower than active region but higher than outer surrounding material. Thus a waveguide channel is formed and optical radiation is directed into the fiber. Figure shows structure of LED

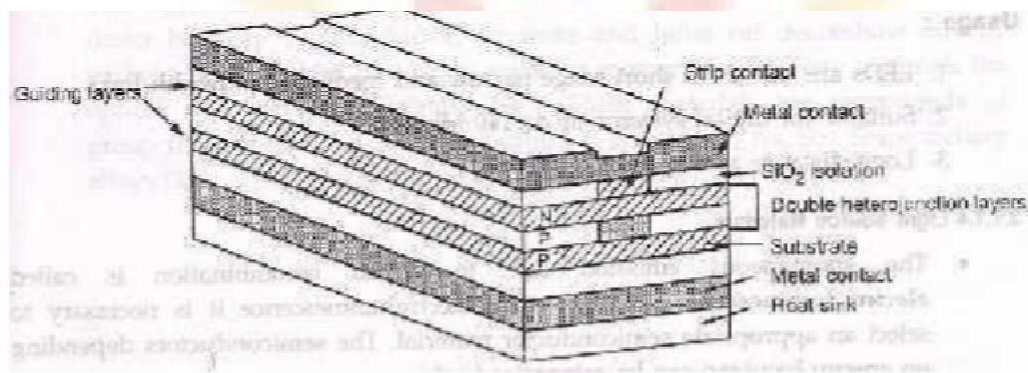

Figure Structure of Edge Emitting LED

Edge emitter's emission pattern is more concentrated (directional) providing improved coupling efficiency. The beam is Lambertian in the plane parallel to the junction but diverges more slowly in the plane perpendicular to the junction. In this plane, the beam divergence is limited. In the parallel plane, there is no beam confinement and the radiation is Lambertian. To maximize the useful output power, a reflector may be placed at the end of the diode opposite the emitting edge.

Features:

- ❖ Linear relationship between optical output and current.
- ❖ Spectral width is 25 to 400 nm for $\lambda = 0.8 - 0.9 \mu\text{m}$.

- ❖ Modulation bandwidth is much large.
- ❖ Not affected by catastrophic gradation mechanisms hence are more reliable.
- ❖ ELEDs have better coupling efficiency than surface emitter.
- ❖ ELEDs are temperature sensitive.

Usage:

1. LEDs are suited for short range narrow and medium bandwidth links.
2. Suitable for digital systems up to 140 Mb/sec.
3. Long distance analog links

Light Source Materials

The spontaneous emission due to carrier recombination is called electro luminescence. To encourage electroluminescence it is necessary to select as appropriate semiconductor material. The semiconductors depending on energy bandgap can be categorized into Direct bandgap semiconductors. Indirect bandgap semiconductors. Some commonly used bandgap semiconductors are shown in following table.

Direct bandgap semiconductors are most useful for this purpose. In direct bandgap semiconductors the electrons and holes on either side of bandgap have same value of crystal momentum. Hence direct recombination is possible. The recombination occurs within 10^{-8} to 10^{-10} sec. In indirect bandgap semiconductors, the maximum and minimum energies occur at different values of crystal momentum. The recombination in these semiconductors is quite slow i.e.

10^{-2} and 10^{-3} sec.

The active layer semiconductor material must have a direct bandgap. In direct bandgap semiconductor, electrons and holes can recombine directly without need of third particle to conserve momentum. In these materials the optical radiation is sufficiently high. These materials are compounds of group III elements (Al, Ga, In) and group V element (P, As, Sb). Some tertiary allos $Ga_{1-x}Al_xAs$ are also used.

Semiconductor	Energy bandgap (eV)	Recombination Br (cm ³ s ec)
GaAs	Direct : 1.43	7.21 x 10 ⁻¹⁰
GaAs	Direct : 0.73	2.39 x 10 ⁻¹⁰
InAs	Direct : 0.35	8.5 x 10 ⁻¹¹
InSb	Direct : 0.18	4.58 x 10 ⁻¹¹
Si	Indirect : 1.12	1.79 x 10 ⁻¹⁵
Ge	Indirect : 0.67	5.25 x 10 ⁻¹⁴
GaP	Indirect : 2.26	5.37 x 10 ⁻¹⁴

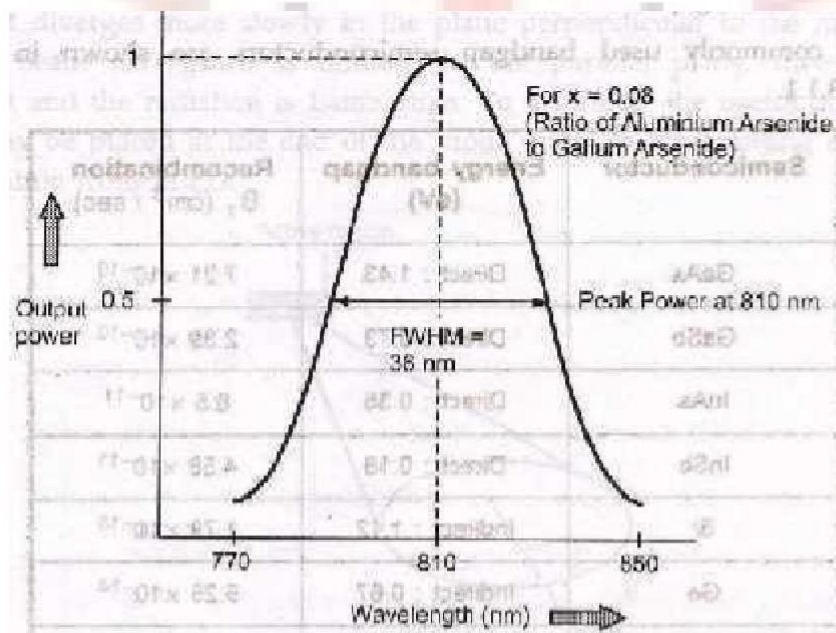

Figure Emission spectrum of Ga_{1-x}Al_xAs LED

The peak output power is obtained at 810 nm. The width of emission spectrum at half power (0.5) is referred as full width half maximum (FWHM) spectral width. For the given LED FWHM is 36 nm. The fundamental quantum mechanical relationship between gap energy E and frequency ν is given as

$$E = h\nu$$

$$E = h \frac{c}{\lambda}$$

$$\lambda = \frac{hc}{E}$$

Where, energy (E) is in joules and wavelength (λ) is in meters. Expressing the gap energy (E_g) in electron volts and wavelength (λ) in micrometers for this application.

$$\lambda(\mu\text{m}) = \frac{1.24}{E_g(\text{eV})}$$

Different materials and alloys have different band gap energies. The bandgap energy (E_g) can be controlled by two compositional parameters x and y , within direct bandgap region. The quaternary alloy $\text{In}_{1-x}\text{Ga}_x\text{As}_y\text{P}_{1-y}$ is the principal material used in such LEDs. Two expressions relating E_g and x, y are

$$E_g = 1.424 + 1.266x + 0.266x^2$$

$$E_g = 1.35 - 0.77y + 0.17y^2$$

Quantum Efficiency and Power

The internal quantum efficiency (η_{int}) is defined as the ratio of radiative recombination rate to the total recombination rate.

$$\eta_{\text{int}} = \frac{R_r}{R_r + R_{\text{nr}}}$$

Where, R_r is radiative recombination rate.

R_{nr} is non-radiative recombination rate.

$$\tau_r = \frac{n}{R_r}$$

If n are the excess carriers, then radiative life time, and non-radiative life time,

$$\tau_{nr} = \frac{n}{R_{nr}}$$

The internal quantum efficiency is given and the recombination time of carriers in active region is τ

It is also known as bulk recombination life time.

$$\eta_{int} = \frac{1}{1 + \frac{R_{nr}}{R_r}}$$

$$\frac{1}{\tau} = \frac{1}{\tau_r} + \frac{1}{\tau_{nr}}$$

$$\eta_{int} = \frac{1}{1 + \frac{\tau}{\tau_{nr}}}$$

Therefore internal quantum efficiency is given as

$$\eta_{int} = \frac{\tau}{\tau_r}$$

If the current injected into the LED is I and q is electron charge then total number of recombinations per second is

$$R_r = R_{nr} = \frac{I}{q}$$

$$\eta_{int} = \frac{R_r}{I/q}$$

$$R_r = \eta_{int} \times \frac{I}{q}$$

Optical power generated internally in LED is given as

$$P_{int} = R_r \cdot h \nu$$

$$P_{int} = \left(\eta_{int} \times \frac{I}{q} \right) \cdot h \nu$$

$$P_{int} = \left(\eta_{int} \times \frac{I}{q} \right) \cdot h \frac{c}{\lambda}$$

$$P_{int} = \eta_{int} \frac{hc I}{q \lambda}$$

Not all internally generated photons will be available from output of device. The external quantum efficiency is used to calculate the emitted power. The external quantum efficiency is defined as the ratio of photons emitted from LED to the number of photons generated internally. It is given by equation

$$\eta_{ext} = \frac{1}{n(n+1)^2}$$

The optical output power emitted from LED is given as

$$P = \eta_{ext} \cdot P_{int}$$

$$P = \frac{1}{n(n+1)^2} \cdot P_{int}$$

Bulk Recombination Life time (τ) :

$$\eta_{int} = \frac{\tau}{\tau_r}$$

$$\frac{1}{\tau} = \frac{1}{\tau_r} + \frac{1}{\tau_{nr}}$$

Internal quantum efficiency (η_{int})

$$\eta_{int} = \frac{23.07}{30}$$

$$\eta_{int} = 0.769$$

Internal power level (P_{int}) :

$$P_{int} = \eta_{int} \cdot \frac{hc I}{q\lambda}$$

Advantages of LED

- ❖ Simple design.
- ❖ Ease of manufacture.
- ❖ Simple system integration.
- ❖ Low cost.
- ❖ High reliability.

Disadvantages of LED

- ❖ Refraction of light at semiconductor/air interface.
- ❖ The average life time of a radiative recombination is only a few nanoseconds, therefore
- ❖ Modulation BW is limited to only few hundred megahertz.
- ❖ Low coupling efficiency.
- ❖ Large chromatic dispersion.

WDM

WDM (Wavelength-division Multiplexing) is the technology of combing a number of wavelengths onto the same fiber simultaneously. A powerful aspect of WDM is that each optical channel can carry any transmission format. WDM increases the capacity of a fiber network dramatically. Thus it is recognized as the Layer 1 transport technology in all tiers of the network. The purpose of this article is to give a brief overview of WDM technology and its applications.

NEED OF WDM

Due to the rapid growth in telecommunication links, high capacity and faster data transmission rates over farther distances are required. To meet these demands, network managers are relying more and more on fiber optics. Typically, there are three methods for expanding capacity: installing more cables, increasing system bit rate to multiplex more signals and wavelength division multiplexing. The first method, installing more cables, will be preferred in many cases, especially in metropolitan areas, since fiber has become incredibly inexpensive and installation methods more efficient. But when conduit space is not available or major construction is necessary, this may not be the most cost-effective.

Another way for capacity expansion is to increase system bit rate to multiplex more signals. But increasing system bit rate may not prove cost effective either. Since many systems are already running at SONET OC-48 rates (2.5 GB/s) and upgrading to OC-192 (10 GB/s) is expensive, requires changing out all the electronics in a network, and adds 4 times the capacity, may not be necessary. Thirdly, the WDM has been proved to be the more cost- effective technology. It does not only support current electronics and fibers but also can share fibers by transmitting channels at different wavelengths (colors) of light. Besides, systems are already using fiber optic amplifiers as repeaters also do not require upgrading for most

WDM.

From the above comparison of three methods for expanding capacity, it can easily draw a conclusion that WDM is the best solution to meet the demand for more capacity and faster data transmission rates. Actually, it is not difficult to understand the operating principle of WDM. Consider the fact that you can see many different colors of light: red, green, yellow, blue, etc. The colors are transmitted through the air together and may mix, but they can be easily separated by using a simple device like a prism. It's like separating the "white" light from the sun into a spectrum of colors with the prism. WDM is equivalent to the prism in the operating principle. A WDM system uses a multiplexer at the transmitter to joint the several signals together. At the same time, it uses a demultiplexer at the receiver to split them apart, as shown in the following diagram. With the right type of fiber, it is possible to function as an optical add-drop multiplexer.

This technique was originally demonstrated with optical fiber in the early 80s. The first WDM systems combined only two signals. Modern systems can handle up to 160 signals and can thus expand a basic 10 Gbit/s system over a single fiber pair to over 1.6 Tbit/s.

Because WDM systems can expand the capacity of the network and accommodate several generations of technology development in optical infrastructure without having to overhaul the backbone network, they are popular with telecommunications companies.



CWDM VS DWDM

WDM systems are divided into different wavelength patterns: CWDM (Coarse Wavelength Division Multiplexing) and DWDM (Dense Wavelength Division Multiplexing). There are many differences between CWDM and DWDM: spacings, DFB lasers, and transmission distances. The channel spacings between individual wavelengths transmitted through the same fiber serve as the basis for defining CWDM and DWDM. Typically, the spacing in CWDM systems is 20 nm, while most DWDM systems today offer 0.8 nm (100 GHz) wavelength separation according to the ITU standard.

Due to wider CWDM channel spacing, the number of channels (λ s) available on the same link is significantly reduced, but the optical interface components do not have to be as precise as DWDM components. CWDM equipment is thus significantly cheaper than DWDM equipment. Both CWDM and DWDM architectures utilize the DFB (Distributed Feedback Lasers). However, CWDM systems use DFB lasers that are not cooled. These systems typically operate from 0 to 70°C with the laser wavelength drifting about 6 nm over this range. Coupled with the laser wavelength of up to ± 3 nm, the wavelength drift yields a total wavelength variation of about ± 12 nm.

DWDM systems, on the other hand, require the larger cooled DFB lasers, because a semiconductor laser wavelength drifts about 0.08 nm/°C with temperature. DFB lasers are cooled to stabilize the wavelength from outside the passband of the multiplexer and demultiplexer filters as the temperature fluctuates in DWDM systems. Due to the unique attributes of CWDM and DWDM, they are deployed for different transmission distances. Typically, CWDM can travel anywhere up to about 160 km. If this needs to transmit the data over a long range, the DWDM system is the best choice. DWDM supports 1550 nm wavelength size, which can be amplified to extend transmission distance to hundreds of kilometers.

OPERATIONAL PRINCIPLES OF WDM

Since the spectral width of a high-quality source occupies only a narrow slice of optical bandwidth, there are many independent operating regions across the spectrum, ranging from the a-band through the L-band, that can be used simultaneously. The original use of WDM was to upgrade the capacity of installed point-to-point transmission links. This was achieved with wavelengths that were separated from several tens up to 200 nm in order not to impose strict wavelength-tolerance requirements on the different laser sources and the receiving wavelength splitters.

Subsequently, the development of lasers that have extremely narrow spectral emission widths allowed wavelengths to be spaced less than a nanometer apart. This is the basis of wavelength-division multiplexing, which simultaneously uses a number of light sources, each emitting at a slightly different peak wavelength.

Each wavelength carries an independent signal, so that the link capacity is increased greatly. The main trick is to ensure that the peak wavelength of a source is spaced sufficiently far from its neighbor so as not to create interference between their spectral extents. Equally important is the requirement that during the operation of a system these peak wavelengths do not drift into the spectral territory occupied by adjacent channels. In addition to maintaining strict control of the wavelength, system designers include an empty guard band between the channels as an operations safety factor. Thereby the fidelities of the independent messages from each source are maintained for subsequent conversion to electrical signals at the receiving

end.

WDM Operating Regions

The possibility of having an extremely high-capacity link by means of WDM can be seen by examining the characteristics of a high-quality optical source. As an example, a distributed-feedback (DFB) laser has a frequency spectrum on the order of 1 MHz, which is equivalent to a spectral line width of 10-5 nm. With such spectral widths, simplex systems make use of only a tiny portion of the transmission bandwidth capability of a fiber. This can be seen from Figure which depicts the attenuation of light in a silica fiber as a function of wavelength. The curve shows that the two low-loss regions of a standard G.652 single-mode fiber extend over the O-band wavelengths ranging from about 1270 to 1350 nm (originally called the second window) and from 1480 to 1600 nm (originally called the third window). This can view these regions either in terms of spectral width (the wavelength band occupied by the light signal) or by means of optical bandwidth (the frequency band occupied by the light signal).

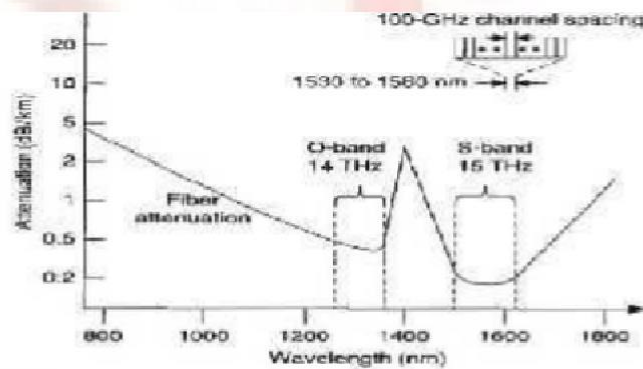

Figure Generic representation of attenuation of light in a silica fiber as a function of wavelength

To find the optical bandwidth corresponding to a particular spectral width in these regions, This uses the fundamental relationship $c = \lambda \nu$, which relates the wavelength λ to the carrier frequency ν , where c is the speed of light. Differentiating this,

$$\Delta \nu = \frac{c}{\lambda^2} \Delta \lambda$$

Where the frequency deviation corresponds to wavelength deviation around the wavelength

If fiber has the attenuation characteristic shown in Figure. The optical bandwidth is $\Delta \nu = 14 \text{ THz}$ for a usable spectral band. $\Delta \lambda = 80 \text{ nm}$ in the center of the O-band. Similarly, $\Delta \nu = 15 \text{ THz}$ for a usable spectral band $\Delta \lambda = 120 \text{ nm}$ in the low-loss region

running from near the beginning of the S-band to almost the end of the L-band. This yields a total available fiber bandwidth of about 30 THz in the two low-loss windows.

Prior to about 2000, the peak wavelengths of adjacent light sources typically were restricted to be separated by 0.8 to 1.6 nm (100 to 200 GHz) in a WDM system. This was done to take into account possible drifts of the peak wavelength due to aging or temperature effects, and to give both the manufacturer and the user some leeway in specifying and choosing the precise peak emission wavelength. The next generation of WDM systems specified both narrower and much wider channel spacings depending on the application and on the wavelength region being used. The much narrower spacings thus require strict wavelength control of the optical source. On the other hand, the wider wavelength separations offer inexpensive WDM implementations since wavelength control requirements are relaxed significantly.

Generic WDM Link

The implementation of WDM networks requires a variety of passive and/or active devices to combine, distribute, isolate, add, drop, attenuate, and amplify optical power at different wavelengths. Passive devices require no external electric power or control for their operation, so they have a fixed application in WDM networks. These passive components are used to separate and combine wavelength channels, to divide optical power onto a number of fiber lines, or to tap off part of an optical signal for monitoring purposes. The performance of active devices can be controlled electronically, thereby providing a large degree of network flexibility. Active WDM components include tunable optical filters, tunable light sources, configurable add/drop multiplexers, dynamic gain equalizers, and optical amplifiers.

The transmitting side has a series of independently modulated fixed-wavelength light sources, each of which emits signals at a unique wavelength. Here a multiplexer (popularly called a mux) is needed to combine these optical outputs into a continuous spectrum of signals and couple them onto a single fiber. Within a standard telecommunication link there may be various types of optical amplifiers, a variety of specialized active components (not shown), and passive optical power splitters. The operations and maintenance benefits of PONs are that no active devices are used between the transmitting and receiving endpoints.

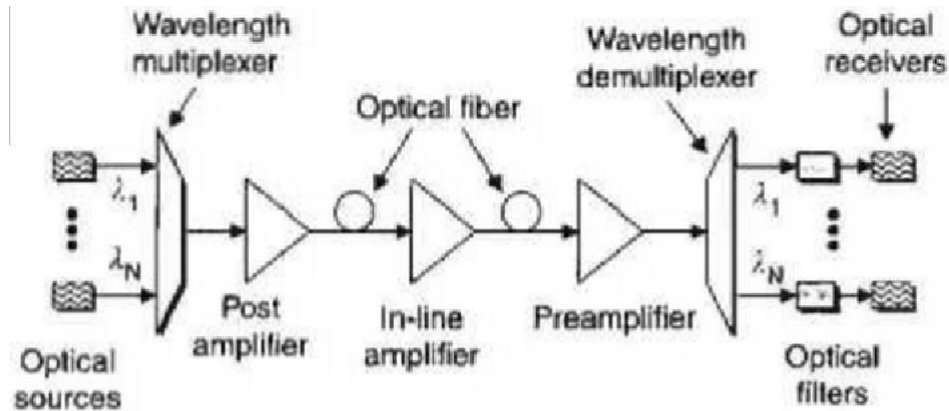

Figure Implementation of a simple WDM link

At the receiving end a demultiplexer is required to separate the individual wavelengths of the independent optical signals into appropriate detection channels for signal processing. At the transmitter the basic design challenge is to have the multiplexer provide a low-loss path from each optical source to the multiplexer output. A different requirement exists for the demultiplexer, since photodetectors usually are sensitive over a broad range of wavelengths, which could include all the WDM channels. To prevent spurious signals from entering a receiving channel, that is, to give good channel isolation of the different wavelengths being used, the demultiplexer must exhibit narrow spectral operation or very stable optical filters with sharp wavelength cutoffs must be used.

The tolerable crosstalk levels between channels can vary widely depending on the application. In general, a -10 dB level is not sufficient, whereas a level of -30 dB is acceptable. In principle, any optical demultiplexer can also be used as a multiplexer. For simplicity, the word multiplexer is used as a general term to refer to both combining and separating functions, except when it is necessary to distinguish the two devices or functions.

Wavelength Division Multiplexing (WDM)

Optical signals of different wavelength (1300-1600 nm) can propagate without interfering with each other. The scheme of combining a number of wavelengths over a single fiber is called wavelength division multiplexing (WDM). Each input is generated by a separate optical source with a unique wavelength. Optical multiplexer couples light from individual sources to the transmitting fiber. At the receiving station, an optical demultiplexer is required to separate the different carriers before photodetection of individual signals. To prevent spurious signals to enter into receiving channel, the demultiplexer must have narrow spectral operation with sharp wavelength cut-offs. The acceptable limit of crosstalk is -30 dB.

Features of WDM

- ❖ Capacity upgrade: Since each wavelength supports independent data rate in Gbps.
- ❖ Transparency: WDM can carry fast asynchronous, slow synchronous, synchronous analog and digital data.
- ❖ Wavelength routing: Link capacity and flexibility can be increased by using multiple wavelength.
- ❖ Wavelength switching: WDM can add or drop multiplexers, cross connects and wavelength converters.

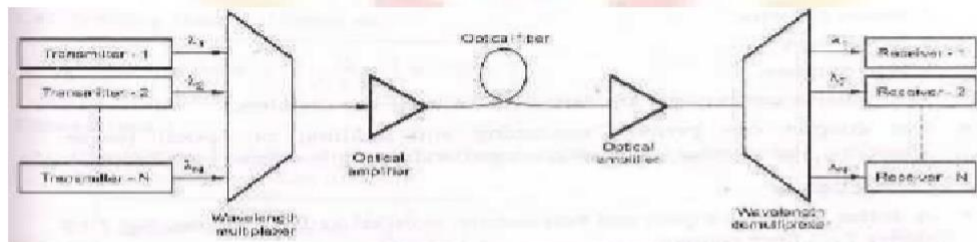

Figure WDM scheme

Passive Components

For implementing WDM various passive and active components are required to combine, distribute, isolate and to amplify optical power at different wavelength. Passive components are mainly used to split or combine optical signals. These components operate in optical domains. Passive components don't need external control for their operation. Passive components are fabricated by using optical fibers by planar optical waveguides. Commonly required passive components are

- ❖ N x N couplers
- ❖ Power splitters
- ❖ Power taps
- ❖ Star couplers.

Most passive components are derived from basic star couplers. Star coupler can perform combining and splitting of optical power. Therefore, star coupler is a multiple input and multiple output port device.