

UNIT-I

Mathematical Modeling of Physical Control systems

Concept of control system

A **control system** manages commands, directs or regulates the behavior of other devices or systems using **control loops**. It can range from a single home heating controller using a **thermostat** controlling a domestic boiler to large **Industrial control systems** which are used for controlling **processes** or machines. A control system is a system, which provides the desired response by controlling the output. The following figure shows the simple block diagram of a control system.



Examples – Traffic lights control system, washing machine

Traffic lights control system is an example of control system. Here, a sequence of input signal is applied to this control system and the output is one of the three lights that will be on for some duration of time. During this time, the other two lights will be off. Based on the traffic study at a particular junction, the on and off times of the lights can be determined. Accordingly, the input signal controls the output. So, the traffic lights control system operates on time basis.

Classification of Control Systems

Based on some parameters, we can classify the control systems into the following ways.

Continuous time and Discrete-time Control Systems

- Control Systems can be classified as continuous time control systems and discrete time control systems based on the **type of the signal** used.
- In **continuous time** control systems, all the signals are continuous in time. But, in **discrete time** control systems, there exists one or more discrete time signals.

SISO and MIMO Control Systems

- Control Systems can be classified as SISO control systems and MIMO control systems based on the **number of inputs and outputs** present.

- **SISO** (Single Input and Single Output) control systems have one input and one output. Whereas, **MIMO** (Multiple Inputs and Multiple Outputs) control systems have more than one input and more than one output.

Open Loop and Closed Loop Control Systems

Control Systems can be classified as open loop control systems and closed loop control systems based on the **feedback path**.

In **open loop control systems**, output is not fed-back to the input. So, the control action is independent of the desired output.

The following figure shows the block diagram of the open loop control system.

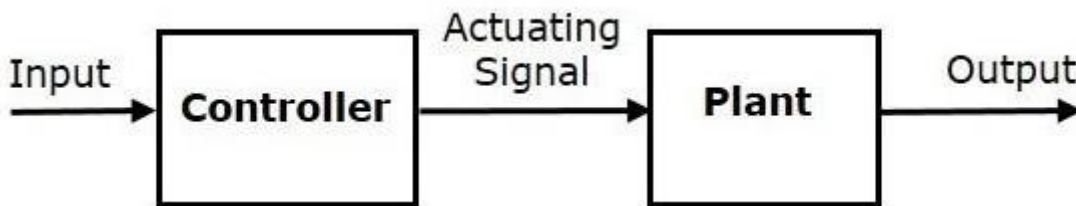

Here, an input is applied to a controller and it produces an actuating signal or controlling signal. This signal is given as an input to a plant or process which is to be controlled. So, the plant produces an output, which is controlled. The traffic lights control system which we discussed earlier is an example of an open loop control system.

In **closed loop control systems**, output is fed back to the input. So, the control action is dependent on the desired output.

The following figure shows the block diagram of negative feedback closed loop control system.

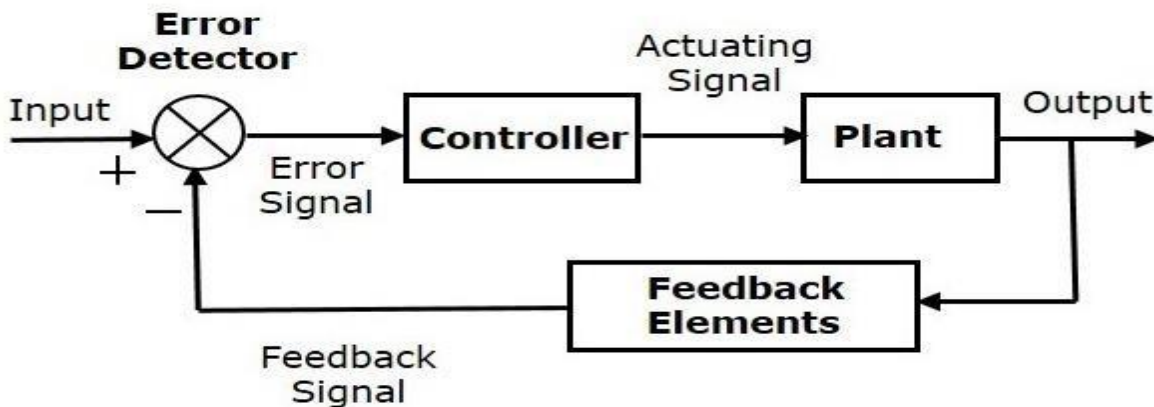

The error detector produces an error signal, which is the difference between the input and the feedback signal. This feedback signal is obtained from the block (feedback elements) by considering the output of the overall system as an input to this block. Instead of the direct input, the error signal is applied as an input to a controller.

So, the controller produces an actuating signal which controls the plant. In this combination, the output of the control system is adjusted automatically till we get the desired response. Hence, the closed loop control systems are also called the automatic control systems. Traffic lights control system having sensor at the input is an example of a closed loop control system.

The differences between the open loop and the closed loop control systems are mentioned in the following table.

Open Loop Control Systems	Closed Loop Control Systems
Control action is independent of the desired output.	Control action is dependent of the desired output.
Feedback path is not present.	Feedback path is present.
These are also called as non-feedback control systems .	These are also called as feedback control systems .
Easy to design.	Difficult to design.
These are economical.	These are costlier.
Inaccurate.	Accurate.

If either the output or some part of the output is returned to the input side and utilized as part of the system input, then it is known as **feedback**. Feedback plays an important role in order to improve the performance of the control systems. In this chapter, let us discuss the types of feedback & effects of feedback.

Types of Feedback

There are two types of feedback –

- Positive feedback
- Negative feedback

Positive Feedback

The positive feedback adds the reference input, $R(s)$ and feedback output. The following figure shows the block diagram of **positive feedback control system**

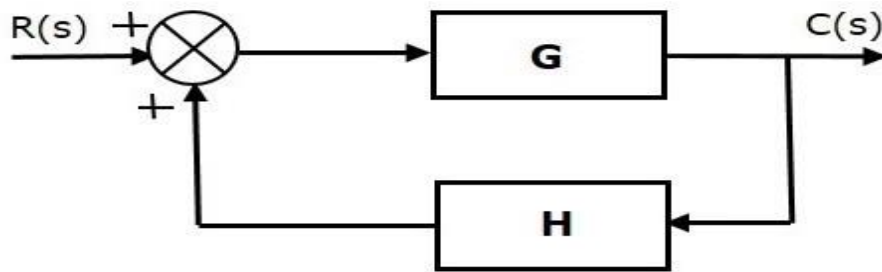

The concept of transfer function will be discussed in later chapters. For the time being, consider the transfer function of positive feedback control system is,

$$T = \frac{G}{1-GH} \quad (\text{Equation 1})$$

Where,

- **T** is the transfer function or overall gain of positive feedback control system.
- **G** is the open loop gain, which is function of frequency.
- **H** is the gain of feedback path, which is function of frequency.

Negative Feedback

Negative feedback reduces the error between the reference input, $R(s)$ and system output. The following figure shows the block diagram of the **negative feedback control system**.

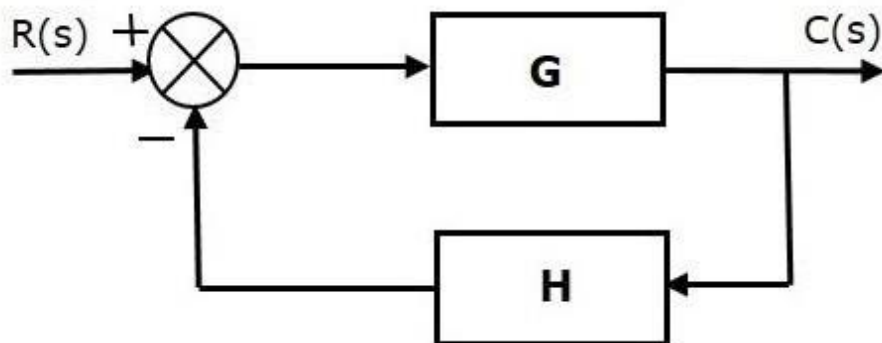

Transfer function of negative feedback control system is,

$$T = \frac{G}{1+GH} \quad (\text{Equation 2})$$

Where,

- **T** is the transfer function or overall gain of negative feedback control system.
- **G** is the open loop gain, which is function of frequency.
- **H** is the gain of feedback path, which is function of frequency.

The derivation of the above transfer function is present in later chapters.

Effects of Feedback

Let us now understand the effects of feedback.

Effect of Feedback on Overall Gain

- From Equation 2, we can say that the overall gain of negative feedback closed loop control system is the ratio of 'G' and (1+GH). So, the overall gain may increase or decrease depending on the value of (1+GH).
- If the value of (1+GH) is less than 1, then the overall gain increases. In this case, 'GH' value is negative because the gain of the feedback path is negative.
- If the value of (1+GH) is greater than 1, then the overall gain decreases. In this case, 'GH' value is positive because the gain of the feedback path is positive.

In general, 'G' and 'H' are functions of frequency. So, the feedback will increase the overall gain of the system in one frequency range and decrease in the other frequency range.

Effect of Feedback on Sensitivity

Sensitivity of the overall gain of negative feedback closed loop control system (**T**) to the variation in open loop gain (**G**) is defined as

$$S_G^T = \frac{\frac{\partial T}{T}}{\frac{\partial G}{G}} = \frac{\text{Percentage change in } T}{\text{Percentage change in } G} \quad (\text{Equation 3})$$

Where, ∂T is the incremental change in T due to incremental change in G.

We can rewrite Equation 3 as

$$S_G^T = \frac{\partial T}{\partial G} \frac{G}{T} \quad (\text{Equation 4})$$

Do partial differentiation with respect to G on both sides of Equation 2.

$$\frac{\partial T}{\partial G} = \frac{\partial}{\partial G} \left(\frac{G}{1+GH} \right) = \frac{(1+GH) \cdot 1 - G(H)}{(1+GH)^2} = \frac{1}{(1+GH)^2} \quad (\text{Equation 5})$$

From Equation 2, you will get

$$\frac{G}{T} = 1 + GH \quad (\text{Equation 6})$$

Substitute Equation 5 and Equation 6 in Equation 4.

$$S_G^T = \frac{1}{(1+GH)^2} (1+GH) = \frac{1}{1+GH}$$

So, we got the **sensitivity** of the overall gain of closed loop control system as the reciprocal of (1+GH). So, Sensitivity may increase or decrease depending on the value of (1+GH).

- If the value of (1+GH) is less than 1, then sensitivity increases. In this case, 'GH' value is negative because the gain of feedback path is negative.
- If the value of (1+GH) is greater than 1, then sensitivity decreases. In this case, 'GH' value is positive because the gain of feedback path is positive.

In general, 'G' and 'H' are functions of frequency. So, feedback will increase the sensitivity of the system gain in one frequency range and decrease in the other frequency range. Therefore, we have to choose the values of 'GH' in such a way that the system is insensitive or less sensitive to parameter variations.

Effect of Feedback on Stability

- A system is said to be stable, if its output is under control. Otherwise, it is said to be unstable.
- In Equation 2, if the denominator value is zero (i.e., GH = -1), then the output of the control system will be infinite. So, the control system becomes unstable.

Therefore, we have to properly choose the feedback in order to make the control system stable.

Effect of Feedback on Noise

To know the effect of feedback on noise, let us compare the transfer function relations with and without feedback due to noise signal alone.

Consider an **open loop control system** with noise signal as shown below.

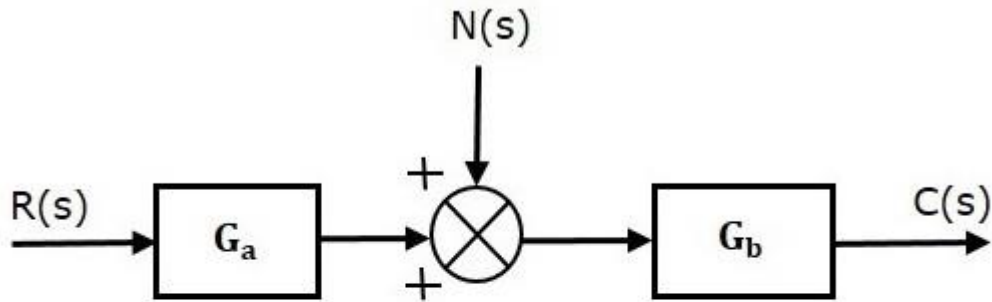

The **open loop transfer function** due to noise signal alone is

$$\frac{C(s)}{N(s)} = G_b \quad \text{(Equation 7)}$$

It is obtained by making the other input $R(s)$ equal to zero.

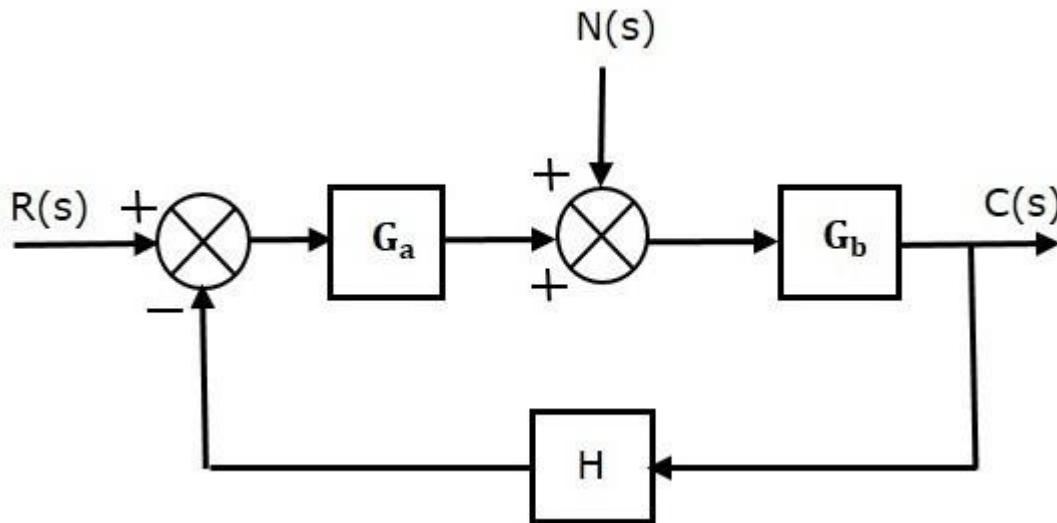

The **closed loop transfer function** due to noise signal alone is

$$\frac{C(s)}{N(s)} = \frac{G_b}{1 + G_a G_b H} \quad \text{(Equation 8)}$$

It is obtained by making the other input $R(s)$ equal to zero.

Compare Equation 7 and Equation 8,

In the closed loop control system, the gain due to noise signal is decreased by a factor of $(1 + G_a G_b H)$ provided that the term $(1 + G_a G_b H)$ is greater than one.

The control systems can be represented with a set of mathematical equations known as **mathematical model**. These models are useful for analysis and design of control systems. Analysis of control system means finding the output when we know the input and mathematical model. Design of control system means finding the mathematical model when we know the input and the output.

The following mathematical models are mostly used.

- Differential equation model
- Transfer function model
- State space model